

# Karakterizacija i kultivacija knock-out sojeva bakterije *Escherichia coli*

---

**Brkan, Katarina**

**Master's thesis / Diplomski rad**

**2017**

*Degree Grantor / Ustanova koja je dodijelila akademski / stručni stupanj:* **University of Zagreb, Faculty of Food Technology and Biotechnology / Sveučilište u Zagrebu, Prehrambeno-biotehnološki fakultet**

*Permanent link / Trajna poveznica:* <https://urn.nsk.hr/urn:nbn:hr:159:750958>

*Rights / Prava:* [In copyright](#)/[Zaštićeno autorskim pravom.](#)

*Download date / Datum preuzimanja:* **2024-07-10**



*Repository / Repozitorij:*

[Repository of the Faculty of Food Technology and Biotechnology](#)



UNIVERSITY OF ZAGREB  
FACULTY OF FOOD TECHNOLOGY AND BIOTECHNOLOGY

# GRADUATE THESIS

Zagreb, November 2017.

Katarina Brkan

869 / BPI

**CHARACTERIZATION AND  
CULTIVATION OF SECRETING  
KNOCK-OUT STRAINS OF**  
*Escherichia coli*

This thesis was made at the University of Bielefeld, Faculty of Technology, The Chair of Fermentation Engineering under the guidance of Apl. Prof. Dr. techn. Karl Friehs and prof. Božidar Šantek and with the help of M. Sc. Gabriele Kleiner-Grote.

## ACKNOWLEDGEMENTS

I thank prof. dr. sc. Karl Friehs for accepting me as his student at the first place, for his numerous advices and encouragement. I also thank M. Sc. Gabriele Kleiner-Grote for being volunteer reviewer, for the patience and advices that made me to do more and better.

Also, I thank the staff of the Laboratory of Fermentation technology for accepting me as one of them, especially to Eberhard Wunsch who made my days brighter and experiments easier and dipl. ing. Thomas Schäffer for his patience and help during never-ending bioreactor cultivations. Specials thanks also to the student of the Laboratory, Julian Schmitz, for his selfless help and everyday discussions. Last but not least, thanks to dr.sc. Dominik Cholewa for his help, encouragement and being the best office partner ever.

Zahvaljujem mentoru prof. dr. sc. Božidaru Šanteku na savjetima i pomoći, a ponajviše jer mi je svojom preporukom omogućio odlazak u Bielefeld.

Zahvaljujem također i svojoj obitelji čije strpljenje, ljubav i potpora nikada nisu izostali. Najveće hvala mojoj mami bez koje ne bih postigla sve što jesam.

# TEMELJNA DOKUMENTACIJSKA KARTICA

Diplomski rad

Sveučilište u Zagrebu

Prehrambeno-biotehnološki fakultet

Zavod za biokemijsko inženjerstvo

Laboratorij za biokemijsko inženjerstvo, industrijsku mikrobiologiju i tehnologiju slada i piva

Znanstveno područje: Biotehničke znanosti

Znanstveno polje: Biotehnologija

## KARAKTERIZACIJA I KULTIVACIJA *KNOCK-OUT* SOJEVA BAKTERIJE *Escherichia coli*

Katarina Brkan, 869 / BPI

**Sažetak:** *Escherichia coli* je jedan od najčešće korištenih mikroorganizama za proizvodnju rekombinantnih proteina od kojih su mnogi intracelularni. Kako bi se izbjeglo mehaničko razbijanje stanica, olakšala izolacija i pročišćavanje proteina pokušava se unaprijediti proces ekstracelularne proizvodnje proteina. Jedan od pristupa, primijenjen i istražen u ovom radu je korištenje takozvanih *leaky* mutanata. Zbog mutacija u genima koji kodiraju za proteine stanične stijenke, ovi mutanti bi trebali pokazivati povećanu sposobnost izlučivanja proteina iz periplazme u hranjivu podlogu nakon translokacije proteina prirodno prisutnim bakterijskim translokacijskim mehanizmima. Četiri *knock-out* soja bakterije *E. coli* su kultivirani najprije u tikvicama a zatim i u bioreaktorima. Kultivirani sojevi su karakterizirani obzirom na rast, koncentraciju proizvedenog proteina i sposobnost sekrecije koristeći fitazu kao *reporter* protein.

**Ključne riječi:** *E. coli*, stanična stijenka, sekrecija proteina, *leaky* mutanti, fitaza

**Rad sadrži:** 72 stranica, 30 slika, 18 tablica, 109 literaturnih navoda, 3 priloga

**Jezik izvornika:** engleski

**Rad je u tiskanom i elektroničkom (pdf format) obliku pohranjen u:** Knjižnica Prehrambeno-biotehnološkog fakulteta, Kačićeva 23, Zagreb

**Mentor na Prehrambeno-biotehnološkom fakultetu:** prof. dr. sc. Božidar Šantek

**Neposredni voditelj:** prof. dr. sc. Karl Friehs (Universität Bielefeld)

**Pomoć pri izradi:** Gabriele Kleiner-Grote, mag. ing. (Universität Bielefeld)

**Stručno povjerenstvo za ocjenu i obranu:**

1. Prof.dr.sc. Blaženka Kos
2. Prof.dr.sc. Božidar Šantek
3. Izv.prof.dr.sc. Tonči Rezić
4. Doc.dr.sc. Andreja Leboš - Pavunc (zamjena)

**Datum obrane:** 08. 12. 2017.

## BASIC DOCUMENTATION CARD

Graduate Thesis

**University of Zagreb**  
**Faculty of Food Technology and Biotechnology**  
**Department of Biochemical Engineering**  
**Laboratory for Biochemical Engineering, Industrial Microbiology and Malting and Brewing Technology**

**Scientific area:** Biotechnical Sciences

**Scientific field:** Biotechnology

### **CHARACTERIZATION AND CULTIVATION OF SECRETING *KNOCK-OUT* STRAINS OF *Escherichia coli***

*Katarina Brkan, 869 / BPI*

**Abstract:** *Escherichia coli* is one of the most commonly used microorganisms for production of recombinant proteins due to its numerous advantages. Many of the recombinant proteins *E. coli* produces are intracellular. To avoid cell disruption, ease protein yielding and purification, there have been attempts in improving extracellular protein production. One of the approaches, applied and investigated in this thesis, is using so-called *leaky* mutants. Due to mutations in genes encoding for proteins of the cell membrane, these mutants show an increased protein release from periplasm to nutrient medium after protein has been translocated by using natural bacterial translocation systems. Four *E. coli knock-out* strains have been cultivated first in flasks and then in bioreactors. Strains have been characterized regarding to their growth, protein production and secretion ability, using phytase as reporter protein.

**Keywords:** *E. coli*, cell wall, secretion, leaky mutants, phytase

**Thesis contains:** 72 pages, 30 figures, 18 tables, 109 references, 3 supplements

**Original in:** English

**Graduate Thesis in printed and electronic (pdf format) version is deposited in:** Library of the Faculty of Food Technology and Biotechnology, Kačićeva 23, Zagreb.

**Mentor at Faculty of Food Technology and Biotechnology:** Božidar Šantek, PhD, Full professor

**Principal investigator:** Karl Friehs, PhD, Prof.

**Technical support and assistance:** Gabriele Kleiner-Grote, M. Sc.

#### **Reviewers:**

1. Blaženka Kos, PhD., Full professor
2. Božidar Šantek, PhD., Full professor
3. Tonči Rezić, PhD., Associate professor
4. Andreja Leboš - Pavunc, PhD., Assistant professor (substitute)

**Thesis defended:** 08. 12. 2017.

## TABLE OF CONTENTS

<b>1. INTRODUCTION</b>	<b>1</b>
<b>2. THEORETICAL BACKGROUND</b>	<b>2</b>
2.1. <i>Escherichia coli</i>	2
2.1.1. Composition of cell wall	2
2.2. Secretion system	4
2.2.1. Protein translocation pathways: Sec and Tat	6
2.3. Recombinant protein production in <i>E. coli</i>	9
2.4. Strains	13
2.4.1. KEIO collection	13
2.4.2. <i>Escherichia coli</i> W3110	15
2.5. Phytase AppA	15
2.6. Bioreactor cultivation of <i>Escherichia coli</i>	18
<b>3. MATERIALS AND METHODS</b>	<b>22</b>
3.1. Chemicals	22
3.2. Devices and lab consumables	23
3.3. Software	25
3.4. Growth media	25
3.5. Plasmid	26
3.6. Bacterial strains	27
3.7. Methods	27
3.7.1. Preculture setting	27
3.7.2. Strain stock	27
3.7.3. Flask cultivation	28
3.7.4. Bioreactor cultivation	28
3.7.5. Cell lysis	29
3.8. Analytical methods	30
3.8.1. Optical density measurement	30
3.8.2. Microscopy	30
3.8.3. Plasmid stability test	30
3.8.4. Enzyme activity test	30
3.8.5. Total protein quantitation – modified Bradford’s protein assay	32
3.8.6. SDS – PAGE	33
<b>4. RESULTS AND DISCUSSION</b>	<b>35</b>
4.1. Flask cultivation of different <i>E. coli</i> strains	35
4.1.1. Growth behaviour and OD <sub>600</sub>	35
4.1.2. Enzyme activity and percentage of secretion	37



4.1.3.	Total protein production and secretion .....	40
4.1.4.	SDS – PAGE.....	43
4.1.5.	Plasmid stability.....	46
4.2.	Bioreactor cultivation.....	47
4.2.1.	Bioreactor cultivation of <i>Escherichia coli</i> $\Delta ompA$ $\Delta ompC$ pAppA1 .....	48
4.2.2.	Bioreactor cultivation of <i>E. coli</i> $\Delta lpp$ pAppA1.....	51
4.2.3.	Enzyme assay results .....	54
4.2.4.	Protein concentration assay.....	57
4.2.5.	SDS – PAGE.....	58
<b>5.</b>	<b>CONCLUSION AND OUTLOOK.....</b>	<b>60</b>
<b>6.</b>	<b>BIBLIOGRAPHY.....</b>	<b>62</b>
<b>7.</b>	<b>APPENDIX.....</b>	<b>70</b>

# 1. INTRODUCTION

*Escherichia coli* is one of the most commonly used microorganisms for the production of recombinant proteins due to its advantages such as short doubling time, simple genetic manipulation and easy cultivation in common nutrient media. Since *E. coli* is a Gram-negative bacterium, the cell envelope consists of two membranes – inner cytoplasmic membrane and outer membrane. Although the cell envelope ensures protection for the cell, it represents a limiting factor for extracellular protein production. Many of the recombinant proteins are produced intracellular, which means they remain in the cytoplasm or periplasm. It makes their yielding complicated by requiring cell disruption and careful protein purification steps in downstream processing. By extracellular protein production, protein yielding from nutrient medium would be facilitated since cell disruption step would be avoided. Another problem successful protein secretion could avoid, is the formation of inclusion bodies that are formed inside of the cell due to high concentrations of recombinant protein.

There have been several approaches to enable and improve extracellular protein production. One of the approaches, applied and investigated in this thesis, is using *leaky* mutants. Due to mutations in genes encoding for proteins of cell membrane and outer membrane proteins, these mutants show an increased protein release from periplasm to nutrient medium after the protein has been translocated by using natural bacterial translocation system.

Within the scope of this thesis, four single and double knock-out mutants, W3110,  $\Delta lpp$ ,  $\Delta ompA \Delta ompC$  and  $\Delta fimD \Delta yghH$ , transformed with pAppA plasmid, have been cultivated and characterized according their growth, protein production and secretion ability with *E. coli* phytase AppA as reporter protein. On this basis, strains that showed the best secretion ability were cultivated in bioreactors. The aim of the second part was to cultivate high cell density batch cultures of selected strains and check protein production and protein secretion potential in a larger volume of 5 and 12 L.

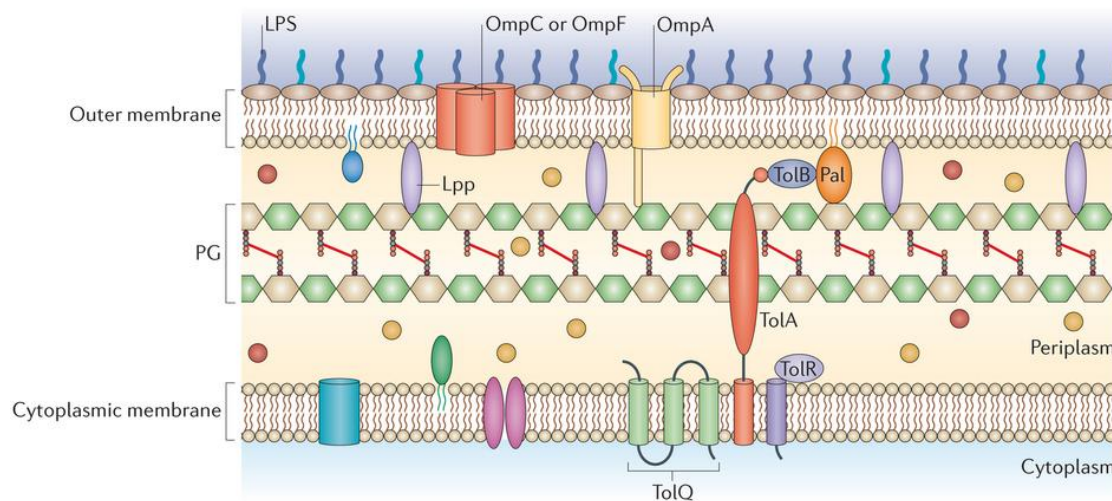
## **2. THEORETICAL BACKGROUND**

### **2.1. *Escherichia coli***

*Escherichia coli* is a Gram-negative, facultative anaerobic, non-sporulating enterobacterium. This coliform bacterium is rod shaped, 2.5  $\mu\text{m}$  long and about 0.8  $\mu\text{m}$  in diameter (Takeuchi *et al.*, 2005). It is a microorganism of huge biotechnological importance being a host for a mass-production of recombinant proteins, important for industrial as well as for pharmaceutical use. Despite the lack of post-translational modification and the existence of endotoxin, this remarkable microorganism has numerous desirable characteristics as a production host such as fast cell growth, easy manipulation, straightforward high cell density cultivation, and capacity to hold over 50 % of foreign protein in total protein expression (Yoon *et al.*, 2010). *Escherichia coli* is a poor secretor of proteins and inadequate secretion is considered one of the most significant barriers of using it as a working microorganism (Ni and Chen, 2009). Important limitation for the production of recombinant proteins in *Escherichia coli* is obtaining large amounts of soluble and functional proteins, especially under overexpression conditions when proteins frequently accumulate as inclusion bodies within the cell (San-Miguel *et al.*, 2013). Because of that, there have been several attempts to improve protein secretion in *E. coli*, which are described in detail in later chapters.

#### **2.1.1. Composition of cell wall**

The bacterial cell membrane is a complex structure composed of multiple layers. Gram-negative bacteria are surrounded by two membranes: inner, cytoplasmic membrane playing a role of osmotic barrier and outer, rigid cell wall which defines form and ensures mechanical strength. Those two membrane layers delimit a compartment called periplasm. In Gram-negative bacteria, the periplasm presents as a relatively thin network (2–7 nm) between the inner and outer membranes. (Gumbart *et al.*, 2014)



Nature Reviews | Microbiology

**Figure 1.** Schematic outline of Gram-negative bacteria cell wall. LPS - lipopolysaccharide, OmpA, OmpC, OmpF – outer membrane protein A, C and F, Lpp – Braun’s lipoprotein, PG – peptidoglycan, Tol-Pal - peptidoglycan-associated lipoprotein which spans the envelope from the cytoplasmic membrane across the periplasm to the outer membrane, composed of TolA, TolB, TolR and TolQ and Pal (Schwechheimer and Kuehn, 2015)

The outer membrane is one of the features that makes the difference between Gram-positive and Gram-negative bacteria. Like other biological membranes, the outer membrane is a lipid bilayer, but importantly, it is not a phospholipid bilayer. The outer membrane does contain phospholipids; they are confined to the inner leaflet of this membrane. The outer leaflet of the outer membrane is composed of glycolipids, principally lipopolysaccharide. (Silhavy *et al.*, 2010) About 50% of the outer membrane mass consists of protein, either in the form of integral membrane proteins or as lipoproteins that are anchored to the membrane by means of N-terminally attached lipids. This includes different enzymes, porines, autotransporter proteins and proteins involved in the biogenesis of flagella and pili (Koebnik *et al.*, 2000). The outer membrane is connected to the peptidoglycan layer with Lpp (murein lipoprotein) proteins as can be seen on Figure 1. Except Lpp, proteins such as OmpA bind peptidoglycan non-covalently as well as Pal protein, peptidoglycan-associated lipoprotein, which is anchored to the outer membrane (Cascales *et al.*, 2002). Peptidoglycan is a polymer made up of repeating units of the disaccharide N-acetyl glucosamine-N-actyl muramic acid. (Silhavy *et al.*, 2010) Because the periplasm is not component of the plasma membrane, it is not part of the protoplast, and because the periplasm is differentiated from the external environment by the outer membrane, it is not part of the “outside.” It is in fact an integral compartment of the gram-

negative cell wall. (Beveridge, 1999) The periplasm is of particular interest in the heterologous expression of recombinant proteins: its non-reducing environment allows disulphide bridges to be formed there and enables the cell to sequester potentially harmful degradative enzymes such as RNase or alkaline phosphatase (Wülfing and Plückthun, 1994; Silhavy *et al.*, 2010) The inner membrane of the Gram-negative bacteria is a phospholipid bilayer with multiple functions. Besides of being a permeability barrier, it is the place of numerous enzyme systems as well as for the energy generation enzyme system (Luirink *et al.*, 2005).

## 2.2. Secretion system

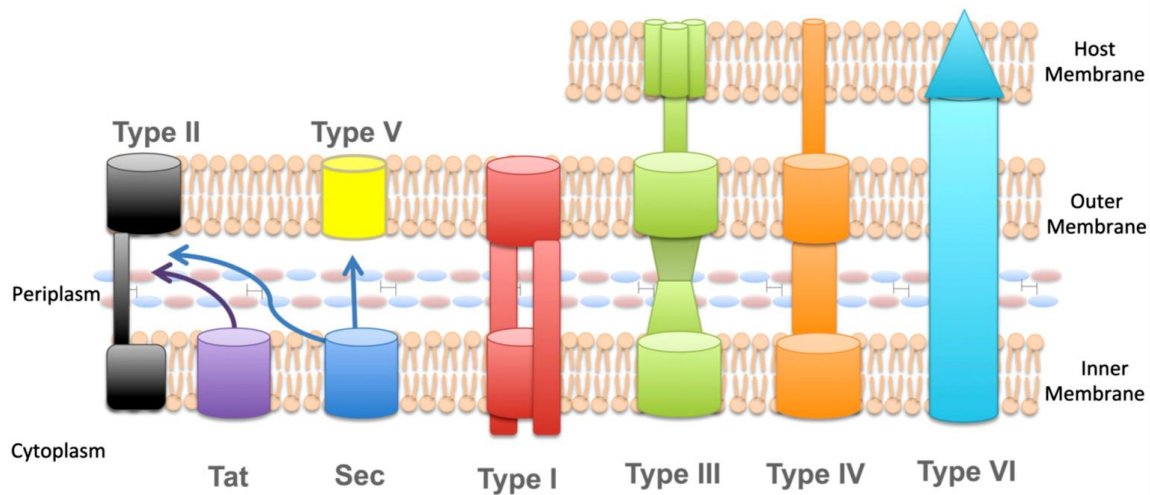
Although *E. coli* cell wall has an important role as a barrier towards the outer environment and gives needed mechanical stability, it complicates secretion out of the cell and consequently, lowers the extracellular protein yield when it comes to large-scale protein production. On the other hand, its porous structure allows transport of wide-range size particles in and out of the cell allowing selective transport. To understand the process of secretion, this chapter gives a short overview of *E. coli* secretion mechanisms.

Secretion represents the transport of proteins through the cell wall. To avoid using some of methods of cell wall disruption that can lower the protein yield at the end, and also, to reduce later purification steps, various genetic attempts have been made to facilitate the extracellular secretion of recombinant proteins in *E. coli*, what is closely explained in later chapters. There are several different classes of bacterial secretion systems, and their designs differ based on whether their protein substrates cross a single phospholipid membrane, two membranes, or even three membranes (Figure 1.), where two are the bacterial and one is a host membrane (Green and Meccas, 2016). Secretion systems can be grouped as one-step and two step secretion mechanisms. Apart from the Type II, all multiple-membrane-spanning secretion systems (Type I, III, IV and VI) use a one-step mechanism, such that substrates are transported directly from the bacterial cytoplasm into the extracellular space or into a target cell (Costa *et al.*, 2015). In *E. coli*, Type I secretion is carried out by a translocator made up of three proteins that span the cell envelope. One of these proteins is a specific outer membrane protein (OMP) and the other two are cytoplasmic membrane proteins: an ATP-binding cassette (ABC) and the so-called membrane fusion protein (MFP). Type I secretion is sec-independent and bypasses the periplasm. Best characterized type I pathway is the one explained on the *E. coli*  $\alpha$ -haemolysin (HlyA) secretion example (Delepelaire, 2004; Gentschev *et al.*, 2002). Type III secretion systems are employed by Gram-negative bacteria to deliver effector proteins into the

cytoplasm of infected host cells, but it can exist without host membrane. Enteropathogenic *E. coli* use this system to deliver effector proteins that result in the creation of the attaching and effacing lesions (Zhou *et al.*, 2014). Type IV secretion system is evolutionarily related to bacterial conjugation systems. It is implicated in the transport of virulent proteins or DNAs in various plant animal or human pathogens, in bacterial conjugation and in DNA uptake or release into the extracellular space facilitating the exchange of genetic material (Rêgo *et al.*, 2010). Type VI secretion system has been shown to be directly involved in bacterial virulence, such as mediating adhesion to host cells as well as for biofilm formation (Journet and Cascales, 2016).

One-step secretion mechanisms are Type II, and V. Type II secretory pathway uses either the general secretory pathway (Sec) or the twin-arginine targeting translocase (Tat) to export proteins across the inner membrane. Specific secretion system machineries are then used for transport of substrates from the periplasm across the outer membrane (Saier, 2006; Rêgo *et al.*, 2010). The type V secretion system, which is also known as the autotransporter system, is unique in that the substrate and its secretion pore are fused to form a single polypeptide. As a result, a single polypeptide can drive its own secretion through the outer membrane, from which the term ‘autotransporter’ is derived. The type V secretion system secretes mainly virulence factors but also participates in cell-to-cell adhesion and biofilm formation (Costa *et al.*, 2015).

Previously mentioned Sec and Tat pathways are translocation mechanisms. Protein translocated to periplasm are released to the medium in different ways. It includes chemical and/or enzymatic methods, sonication or using *leaky* mutants with deleted (or mutated) genes coding for outer membrane proteins, making it more permeable. As the latter approach has been adopted in this thesis, the following chapter gives short overview of protein translocation in *Escherichia coli* as the first step in protein secretion.



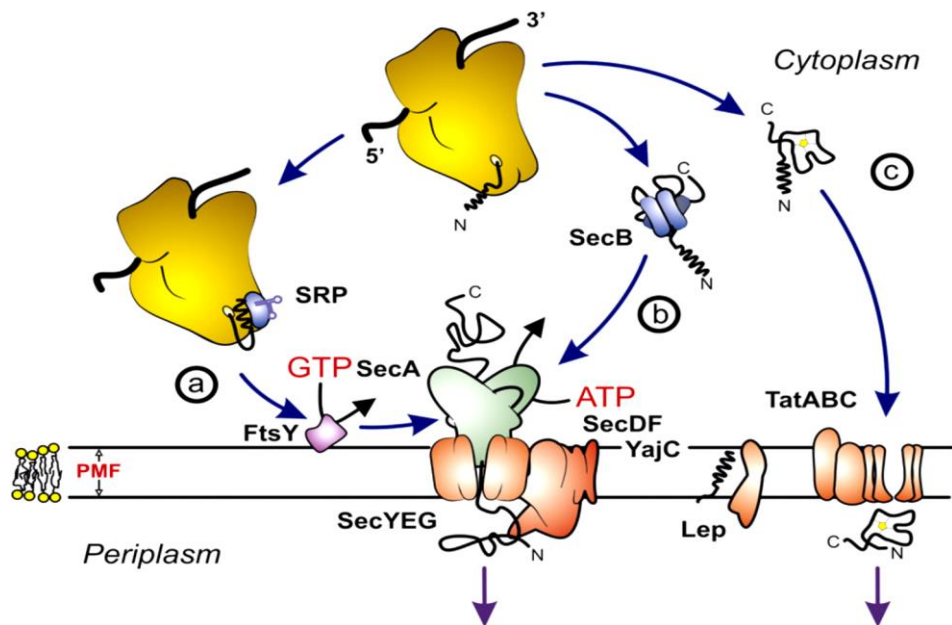
**Figure 2.** *E. coli* secretion system types. (Green and Mecsas, 2016)

### 2.2.1. Protein translocation pathways: Sec and Tat

To preserve its integrity, function as well as optimal ionic composition, there are different transport mechanisms across the cytosolic membrane. The general secretion (Sec) and twin-arginine translocation (Tat) pathways are the bacterial secretion systems most commonly used to transport proteins across the cytoplasmic membrane. They are the most highly conserved mechanisms of protein secretion and have been identified in all domains of life (bacteria, archaea, and eukarya). In Gram-negative bacteria, proteins delivered to the cytoplasmic membrane or periplasm of the cell by the Sec or Tat pathways, can either stay in those compartments, or may be transported outside of the cell. While the Sec and Tat systems have several common elements, they transport proteins by fundamentally different mechanisms (Green and Mecsas, 2016).

The system of the general secretory pathway (Sec) consists of protein targeting components, a motor protein and a membrane integrated protein conducting channel. Its task is exporting unfolded polypeptides. Sec translocase in bacteria is responsible for the secretion of most extracellular proteins that fulfil diverse functions in metabolism, substrate uptake and excretion, cell envelope structure, sensing and cell communication. It is composed of a *protein conducting channel* (PCC), incorporated in the inner membrane, and a peripheral associated ATPase, SecA, that functions as a molecular motor to drive the translocation of secretory proteins across the membrane (Natale *et al.*, 2008). PCC consists of three, highly conserved, integral membrane proteins, SecY, SecE and SecG (Keyzer *et al.*, 2003). Secretory proteins can be targeted to the Sec translocase by two different mechanisms, i.e., the co-translational

and the posttranslational targeting. In the latter, the signal sequence containing secretory protein is released from the ribosome in its synthesis completed state and directed to Sec-translocase (Natale *et al.*, 2008). Posttranslational secretory proteins in Gram-negative bacteria are led to the Sec translocase by the specific chaperone, SecB, that maintains the preprotein in a translocation-competent state that will neither fold nor aggregate (Driessen, 2001). SecB binds to multiple regions of the mature domain of secretory protein and does not interact with the signal peptide region (Randall *et al.*, 1990). Secretory proteins are preferentially targeted via the SecB pathway, while some preproteins with a very hydrophobic signal peptide and most *inner membrane proteins* (IMPs) are targeted by SRP (*signal recognition particle*) (Keyzer *et al.*, 2003). The SRP targets IMPs to the inner membrane in a co-translational fashion. It binds to the signal sequence of the secretory protein while it emerges from the ribosome and the entire ternary complex of SRP/ribosome/nascent secretory protein chain is targeted to Sec translocase. SecA accepts secretory proteins from SecB or from the ribosome and energy needed for this process is provided from ATP and proton motive force (Figure 2.) (Luirink *et al.*, 2005; Natale *et al.*, 2008).



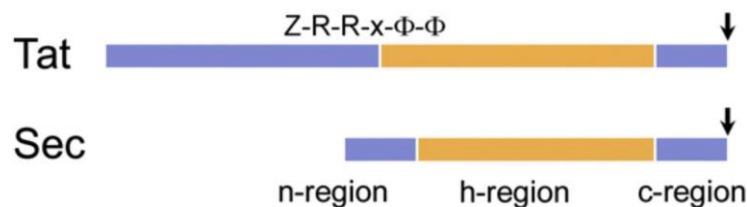
**Figure 3.** Sec and Tat translocation systems. (a) Co-translational and (b) post-translational targeting routes and translocation of unfolded proteins by Sec-translocase. (c) Translocation of folded precursor proteins by the Tat translocase (Natale *et al.*, 2008).

The TAT system is capable of secreting folded proteins (Choi and Lee, 2004) including numerous substrates like different redox enzymes requiring cofactor insertion in cytoplasm, certain membrane proteins and proteins included in anaerobic metabolism and even virulence



(Lee *et al.*, 2006). Proton motive force provides energy needed for this process (Sargent *et al.*, 2001). The minimal set of components required for Tat translocation in *Escherichia coli* consists of three integral membrane proteins: TatA, TatB, and TatC (Lee *et al.*, 2006). TatB and TatC play important roles in substrate binding, (Robinson *et al.*, 2011) while structural features of TatA strongly support the proposal that it is the protein-conducting channel of the Tat system (Gohlke *et al.*, 2005). One of the advantages of secretory protein production is that the authentic N-terminal amino acid sequence without the Met extension can be obtained after cleavage by the signal peptidase, but this can be achieved only when the gene of interest is correctly fused to the cleavage site. On the other hand, obstacles in using secretory pathways for recombinant protein production include incomplete processing of signal sequences, variable secretion efficiency depending on the characteristics of the proteins, low or undetectable amounts of recombinant protein secretion and incorrect formation of disulphide bonds (Choi and Lee, 2004).

Correct targeting of the secretory protein to the translocation pathway depends on amino-terminal extension i.e. the signal peptide. The function of the signal peptide is conserved in all domains of life. Signal peptide has a tripartite structure, i.e., a positively charged amino-terminal (n-region), a hydrophobic core (h-region) and a polar carboxyl-terminal (c-region) region. Tat signal sequences are recognized by a conserved pattern of amino acids which includes two almost invariant arginines – the eponymous twin-arginine motif at the interface of the n-and h- regions (Natale *et al.*, 2008). Additionally, h-region of Tat signal peptides is less hydrophobic than that of Sec-specific signal peptides because of presence of more glycine and threonine residues. Sec signal sequence has an average length of 20 amino acid residues while Tat signal sequences tend to be longer than Sec counterparts (Figure 3.), mostly because of an extended n-region (Cristóbal *et al.*, 1999; Natale *et al.*, 2008).



**Figure 4.** Difference between Tat and Sec signal sequence. Z stands for any polar residue and  $\Phi$  for hydrophobic residues (Natale *et al.*, 2008).

### 2.3. Recombinant protein production in *E. coli*

Recombinant proteins can be produced in mammalian cells cultures or in microbial systems. Obvious advantages of producing recombinant proteins in microbial systems are lower costs and shorter production times. Having a short generation time, being well studied and easily manipulated are all reasons why *E. coli* is most commonly used host. There is a distinction between intracellular and extracellular protein production and following text brings a short overview of important features, advantages and disadvantages of each approach of recombinant protein production.

First approach to recombinant protein production is intracellular production as soluble protein. Some proteins are able to fold spontaneously under cellular conditions, but others are prone to aggregation and require the existence of a number of molecular chaperones that reversibly interact with nascent polypeptide chains, preventing aggregation during the folding. As a result of aggregation of overexpressed recombinant proteins, there is an accumulation of high concentrations of folding intermediates or inefficient processing by molecular chaperones within the cells (Sørensen and Mortensen, 2005). Intracellular production also brings another disadvantage, – the need for whole cell disruption as well as protein purification problems in downstream processing. More purifications steps make total costs higher and protein yield lower. There were attempts such as one from Naglak and Wang who reported using guanidine hydrochloride combined with Triton X-100, where guanidine hydrochloride affects the outer membrane and Triton affects cytoplasmic membrane. They aimed to extend the concept of chemical permeabilization to recovery of a foreign protein in active form from a recombinant strain of *E. coli* and to demonstrate the potential for achieving selectivity in protein release based on intracellular location. It was showed that addition of guanidine with Triton X-100 can extract over 50 % of intracellular protein, indicating that Triton X-100 alone is ineffective at disrupting cells, in accordance with the known detergent resistance of the outer membrane of Gram-negative bacteria (Naglak and Wang, 1990; Tang *et al.*, 2008).

Intracellular recombinant protein production in high concentration, can result in production of inclusion bodies, inactive protein aggregates in the host cell. The tendency of forming inclusion bodies does not correlate with the expressed polypeptide size, subunit structure or relative hydrophobicity, but the overproduction itself triggers their formation (Rudolph and Lilie, 1996). Aggregation is predominant feature in very strong expression systems, but also increases with high inductor concentration, with the use of complex growth media and at higher

cultivation temperature (Fahnert *et al.*, 2004). Formation of inclusion bodies has some advantages. The initial isolation step is relatively simple, and it involves only a disruption and chemical/physical separation to a relatively pure (>50%) product. There is also an evidence that intracellular proteases do not attack the aggregated forms of proteins (Kane and Hartley, 1988). Refolding from inclusion bodies is mostly considered undesirable and it usually requires denaturing conditions that causes problems in subsequent renaturing step (San-Miguel *et al.*, 2013; Sørensen and Mortensen, 2005). Major difficulties are poor recovery yields, the requirement for optimization of refolding conditions for each target protein and the possibility that the re-solubilization procedures could affect the integrity of refolded proteins (Sørensen and Mortensen, 2005). Besides the listed disadvantages, purification of soluble protein expressed in high concentration is cheaper and less time consuming than refolding from inclusion bodies.

Another approach is the secretion of recombinant protein outside of the cell. If it is not one-step process (e.g. type I secretion system), first step to extracellular protein production is translocation of proteins into the periplasm. Periplasmic expression has some advantages over cytoplasmic production: the authentic N-terminus can be obtained after the removal of the signal sequence by leader peptidases, there are fewer proteases in the periplasm and the oxidizing environment of periplasm facilitates the formation of disulphide bonds. Also, the periplasm contains fewer proteins than cytoplasm which makes purification of the target protein easier (Baneyx and Mujacic, 2004). Next obstacle is releasing recombinant proteins from the periplasm into the medium. Traditional methods for recovering periplasmic proteins from *E. coli* involve osmotic shocks or the digestion of the peptidoglycan layer by lysozyme in the presence of ethylenediaminetetraacetic acid (EDTA). The important drawback of the osmotic shock is the demand for several additional centrifugation and resuspension steps which is practical only in small volumes. Except of being time consuming, large volumes are more difficult to handle at low temperatures than small volume samples. What makes lysozyme use repellent is its high price (Jalalirad, 2013; Naglak and Wang, 1990). Using chemical agents for the selective release of proteins expressed in periplasm has been investigated, but the influence of such chemical agents on the biological activity and structure of the pure target proteins has not been investigated prior to *E. coli* cell permeabilization (Jalalirad, 2013).

Aside from chemical and enzyme methods, Ni and Chen summarized four engineering strategies in making extracellular proteins (Ni and Chen, 2009). First method is engineering dedicated secretion systems that naturally exist in *E. coli* (type I-VI). Type I system is

frequently used because of its simplicity where substrate is transported directly to the medium in a one-step process without forming a periplasmic intermediate. Several type I transporters can be used for recombinant protein production, but the *E. coli*  $\alpha$ -haemolysin (HlyA) transporter is by far the most popular. Some examples of secretion of recombinant proteins expressed as fusions to the HlyA signal sequence are interleukin-6 (Li *et al.*, 2002), single-chain variable fragment and single-domain antibodies (Fernandez, 2004) or alkaline phosphatase (Angkawidjaja *et al.*, 2006). Just like type II secretion system, type V secretion system is a two-step process which includes translocation across the IM and a subsequently releasing into the medium through the outer membrane. Zhou *et. al* successfully used *Erwinia chrysanthemi* out (type II) system to secrete an endoglucanase by expressing the entire system in *E. coli* (Zhou *et al.*, 1999). The most widely used laboratory *E. coli* strain, K-12, does not secrete proteins into the extracellular medium under standard growth conditions, despite possessing chromosomal genes encoding a putative type II secretion machinery because it is silenced by the nucleoid – structuring protein H-NS. The use of type V system is also described in case of comparing secretion efficiency of haemolysin by autotransporter system and its usual, type I system (Zhu *et al.*, 2006).

Another strategy is the fusion of the target protein to a carrier protein that is normally secreted into the medium or to the outer membrane. Fusion system was disclosed for the YebF putative lipoprotein (Weiner and Zhang, 2006) and also for human  $\beta$ -Endorphin being fused to OmpF (Jeong and Lee, 2002). Unlike the first strategy, engineering dedicated secretion systems that naturally exist in *E. coli*, the mechanism by which the fusion protein pass through outer membrane is unknown and host factors that influence the transport are not identified. In order to optimize the secretion efficiency, the choice of the right fusion partner is important. Obvious drawback of this method is the need for a cleavage of carrier protein and target protein. Also, the size of the fusion protein could become a limiting factor because large proteins are, in general, more difficult to pass through the membrane (Ni and Chen, 2009). Another way of producing extracellular proteins is the co-expression of lysis-promoting proteins such as Kil or BRP. It is reported that expression of *kil* gene leads to an alteration of the outer cell membrane resulting in release of periplasmic enzymes without cell death. Latter is applied in patent by Miksch *et al.*, where the *kil* gene was fused with a stationary phase promoter and the target  $\alpha$ -glucanase was released into the surrounding media (Suit and Luria, 1988; Miksch *et al.*, 2004). Bacteriocin release proteins (BRP) are small lipoproteins (3 kDa) that activate detergent-resistant phospholipase A, resulting in the formation of permeable zones in the cell envelope

through which proteins are released to the medium (Sommer *et al.*, 2010; Choi and Lee, 2004). Crucial point for using this method is the fine tuning of both promoter's strength and induction time. Summarized, this method is useful because its non-specificity, but at the same time, it is a disadvantage when it comes to purification of a target protein from other periplasmic proteins that leak together with the target protein. Additionally, high expression of Kil or BRP can lead to cell lysis.

Finally, there are *leaky* mutants, where a certain mutation in wild-type strain partially impairs a certain characteristic or function in the mutant, rather than eliminating it completely. *Leaky* mutations can be applied to genes coding for components of outer bacterial membrane. Due to changes in the outer membrane, it becomes more permeable. Changes in the outer membrane can be caused by mutations or deletions of genes related to the biosynthesis of cell wall and membrane, especially of the outer membrane genes such as *lpp* encoding Braun's lipoprotein. As a result, mutant strains release more proteins into the nutrient medium. Besides *lpp*, the genes *pal* (encoding peptidoglycan-associated outer membrane lipoprotein), *mrcA* and *mrcB* (encoding peptidoglycan synthetase) were selected as target genes for genetic manipulation. (Chen *et al.*, 2014). In large-scale production of exogenous proteins, using leaky mutants to excrete target proteins can remove the cell disruption step, offer a better environment for protein folding and reduce the risk of intracellular enzyme degradation. Also, recombinant protein yield is improved because target protein accumulation is not limited in periplasmic or intracellular space. Main disadvantage is that the secretory selectivity is not high, suggesting that these genes affect the structure of the outer membrane but do not participate in the active transport of target protein (Mergulhão *et al.*, 2005). An extreme case of structural cell wall mutation for protein production in *E. coli* are the, so-called, L-forms, used for production of penicillin G acylase (Gumpert and Hoischen, 1998) and staphylokinase (Hoischen *et al.*, 2002). Those strains are able to grow as cell wall-deficient (spheroplast type) or as cell wall-less (protoplast type) cells. Sensitivity of L-cells to environmental influences causes using those cells limited and requires careful handling, especially when it comes to the control of inoculum and the avoidance of contact with membrane-active surfactants (Gumpert and Hoischen, 1998). Another problem is the impossibility of using these cells in high cell density production due to special medium requirements and, as already mentioned, their sensibility to environmental stress which can be expected in large fermentor.

## 2.4. Strains

### 2.4.1. KEIO collection

A set of precisely defined, single-gene deletions of all nonessential genes in *Escherichia coli* K-12 strain BW25113 was made to create the KEIO strain collection. BW25113 is a strain with a well-defined pedigree that has not been subjected to mutagens. Open-reading frame coding regions were replaced with a kanamycin cassette flanked by FLP (flippase) recognition target (FRT) sites by using a one-step method ( $\lambda$  Red system) for inactivation of chromosomal genes and primers designed to create in-frame deletions upon excision of the resistance cassette. Of 4186 genes targeted, mutants were obtained for 3864. Two mutants were saved for each deletion to avoid possible errors or crosscontamination (Baba *et al.*, 2006; Yamamoto *et al.*, 2009). The KEIO collection of all viable *Escherichia coli* single-gene knockouts is facilitating a systematic investigation of the regulation and metabolism of *E. coli* (Long and Antoniewicz, 2014).

*E. coli* JW1667-5 strain has *lpp* deleted which codes for Lpp murein lipoprotein, or Braun's lipoprotein. In *E. coli*, Braun's lipoprotein is the most numerous protein with about 700,000 copies per cell. It provides both covalent and non-covalent mechanisms for the outer membrane to interact with peptidoglycans and contributes significantly to the rigidity of the cell envelopes (Ni *et al.*, 2007). Lpp has a 58 amino acid long sequence organized in  $\alpha$ -helical conformation (Braun, 1975) and exists in both free form and bound form with covalent linkage to the peptidoglycans (Neidhardt *et al.*, op. 1990). The lipids attached to the amino terminus embed this protein in the outer membrane while carboxy-terminal lysine binds protein to peptidoglycan layer (Silhavy *et al.*, 2010). It was shown that *lpp* deletion, rather than mutation, is responsible for enhanced outer membrane permeability. Based on this result, permeabilization method through *lpp* deletion was established and confirmed with substrates of varying hydrophobicity. *lpp* deletion does not significantly affect the cell growth. The only difference in growth was found toward the end of the cultivation. The final cell density was about 20% lower than the control strain without deletion. Additionally, deletion did not significantly affect cell metabolism or cell's ability to express recombinant proteins (Ni *et al.*, 2007). As Shin and Chen described, *lpp* deletion could be used as a method for high percentage extracellular protein production without inducing extensive cell lysis (Shin and Chen, 2008). Leaky strains (including *lpp* deletion strain) were even used to produce full length antibodies form IgG and IgM classes in a yield greater than 160 mg/L without co-expression of a

periplasmic chaperone (Wich and Dassler, 2008). High-percentage secretion of recombinant proteins to extracellular medium was shown for three model proteins, maltose-binding protein (MalE), a xylanase and a cellulase. It was shown that up to 90% of the recombinant xylanase activity was found in growth medium with the deletion mutant whereas only about 40–50% was secreted with the control strain when cells were grown in a bioreactor under identical conditions (Ni and Chen, 2009).

Another strain used in this thesis is double knock-out strain  $\Delta ompA \Delta ompC \Delta kanR$ . Gene *ompA* codes for OmpA – outer membrane protein A, a most well studied, 325-residue, heat-modifiable major outer membrane protein. In addition to its basic structural role (holding peptidoglycan and the outer membrane together as a whole structure), OmpA serves as a receptor for colicin and several phages and it is required in F-conjugation (Wang, 2002). It produces a diffusion channel allowing a slow penetration of small solutes, but pore forming activity of OmpA can be destroyed by the heat denaturation (Sugawara and Nikaido, 1992). Second gene, *ompC* codes for protein OmpC. It belongs to a group of porin proteins which form relatively nonspecific pores which allow diffusion of nutrients across the outer membrane, serve as receptors for various bacteriophages and facilitate the transport of colicins (Misra and Benson, 1988). Structurally similar to another porin protein, OmpF, OmpC is slightly more cation selective than OmpF and its pore has been predicted to be smaller (1,1 nm) (Baslé *et al.*, 2006; Misra and Benson, 1988). Each pore, either OmpF or OmpC excludes molecules larger than 650 daltons and both are regulated by osmotic pressure and temperature (Benson and Decloux, 1985; Cowan *et al.*, 1992). It has been shown that mutations which cause alterations in OmpC protein, result in altered permeability of the outer membrane causing increased sensitivity to various detergents and antibiotics (Benson and Decloux, 1985). Also, loss of OmpC in *E. coli* can promote not only antimicrobial resistance, but also serum resistance which suggests that *E. coli* OmpC has dual functions in pathogenesis when it is lost (Liu *et al.*, 2012).

Double knock-out *E. coli* strain  $\Delta fimD \Delta yghH \Delta kanR$  also has deleted genes that code for outer membrane proteins. Their exact function is still not closely studied but it is known that gene *fimD* codes for outer membrane usher protein which takes part in type 1 fimbrial synthesis in *E. coli* (Anonymous1).

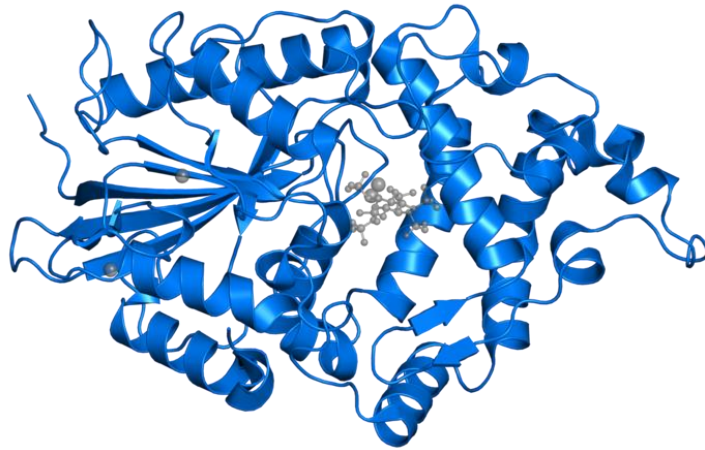
#### **2.4.2. *Escherichia coli* W3110**

*E. coli* W3110 has been used to create a data base of the expression levels of *E. coli* proteins under different growth conditions, for construction of a physical map of the *E. coli* chromosome, and for systematic chromosome sequencing (Jensen, 1993). The first physical map of the whole *E. coli* chromosome was created using a W3110 genomic library (Hayashi *et al.*, 2006). Importance of this strain reflects in definition given in patent Wacker Chemie AG where stands: “Increased leakiness means that the cells show after fermentation a higher concentration of periplasmatic proteins in the nutrient medium than the *E. coli* W3110 strain” (Dassler *et al.*, 2008). In other words, W3110 strain is used as a referent strain to compare secretion ability among other strains used in this thesis because it is considered to be wild-type strain with poor secretion ability (Hayashi *et al.*, 2006).

#### **2.5. Phytase AppA**

Phytases are phosphohydrolases that initiate the step-wise removal of phosphate from phytate (Lei and Porres, 2003). Phytases from *E. coli* were shown to accumulate *myo*-inositol tetrakis- and trisphosphate esters (Greiner, 2017). Phytate is the principal form in which phosphorus and inositol are stored in cereals, legumes used in commercial animal feeds and oilseeds. Phytates constitute circa 60–90 % of the total phosphorus content in plants (Reddy *et al.*, 1982). So far, phytases have been mainly used as a feed supplement in diets for swine and poultry, and to some extent for fish (Yao *et al.*, 2012). Monogastric animals such as pigs and poultry virtually lack phytase activity in their digestive tracts; consequently, feed is commonly supplemented with inorganic phosphate to satisfy the phosphorus requirements. Furthermore, phytic acid is an antinutrient factor, since it can chelate proteins and a variety of metal ions and therefore depress utilization of these nutrients. The undigested phytate also results in phosphorus pollution (Chen *et al.*, 2005). Thus, phytases perform a double duty, conserving expensive and non-renewable inorganic phosphorus resources by reducing the need for their inclusion in animal feed, while also protecting the environment from pollution resulting from excessive manure phosphorus run-off. (Yao *et al.*, 2012)

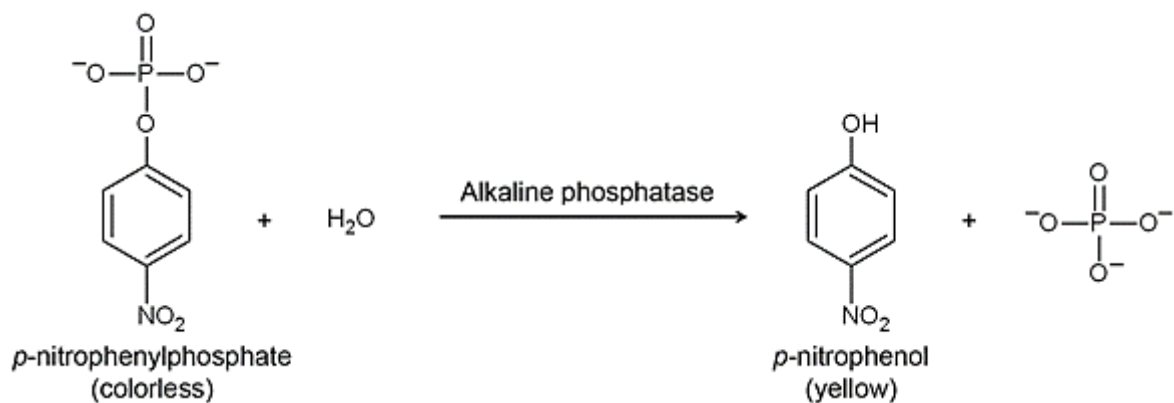




**Figure 5.** Tertiary structure of phytase. (PDBe, 2000)

Phytase is used as reporter protein where its activity can be correlated to secretion ability of working microorganism strain. Therefore, industrial use of phytase will not be further discussed, but the features of this enzyme are important for activity determination. There are two phytases as classified by Nomenclature Committee of the International Union of Biochemistry and Molecular Biology (NC-IUBMB): 3-phytase (EC 3.1.3.8) and 6-phytase (EC 3.1.3.26), initiating the dephosphorylation at the 3 and 6 positions of phytate respectively. (Vohra and Satyanarayana, 2003; Li *et al.*, 2009) *E. coli* phytase is a periplasmatic 6-phytase (Greiner *et al.*, 1993) with a molecular weight of about 45000 (with signal sequence being cleaved) and an isoelectric point of 6.3 (Dassa *et al.*, 1980). For phytase production the optimum pH of most bacteria and fungi is in the range between 5.0 and 7.0 (Vohra and Satyanarayana, 2003) and temperature optimum varies from 40 up to 70 °C, depending on phytase source (fungi, bacteria, yeast or plant) (Yao *et al.*, 2012). Most phytases belong to either the acid phytases or the alkaline phytases, depending on their optimal pH for catalytic activity. All acid phytases (EC 3.1.3.2) are in a subfamily of the high-molecular-weight HAPs (histidine acid phosphatase) (Oh *et al.*, 2004). Enzyme activity assays are based on this acid phosphatase activity where hydrolysis of phosphoric acid esters is catalysed by acid phosphatase activity. *E. coli* AppA protein is an acid phosphomonoesterase with a restricted substrate specificity and optimal pH of 2,5 (Dassa *et al.*, 1980). It is known to exhibit a limited substrate specificity. Substrates possessing phosphoanhydride bonds are preferentially hydrolysed and inorganic polyphosphates are best substrates among those that have been tested (Dassa *et al.*, 1982). Phosphomonoesters appear to be poor substrates but fructose 1,6-diphosphate and *p*-nitrophenyl phosphate seem to be exceptions to the rule (Ostanin *et al.*,

1992). Synthetic substrate *para*-nitrophenyl phosphate stands out (Dassa and Boquet, 1985) being efficiently hydrolysed to chromogenic product *p*-nitrophenol with absorbance at 405 nm.



**Figure 6.** Reaction scheme of the enzymatic reaction of the artificial substrate *p*-nitrophenyl phosphate under acidic conditions by the acidic phosphatase activity of the phytase AppA from *E. coli*. (Anonymous 2, 2017)

## 2.6. Bioreactor cultivation of *Escherichia coli*

Except for being a model microorganism and being used for in vaccine development, biofuel production or bioremediation, a well characterized protein production system placed *E. coli* on the top of the most commonly used host microorganisms for recombinant protein production, as closely explained in previous chapter. Growing demands for *E. coli* products, lead to large scale production consequently to fermentation research. The primary goal of fermentation research is the cost-effective production of desired proteins using high productivity techniques. Higher productivity can mean higher cell density and it can be achieved by using HCDC (*high cell density cultures*) techniques. Aside from improving productivity, HCDC techniques provide advantages such as reduced culture volume, enhanced downstream processing, reduced wastewater, lower production costs and reduced investment in equipment (Lee, 1996).

Many different processes are used to achieve HCDC, such as batch (Strandberg and Enfors, 1991), continuous (Tosa *et al.*, 1974) and semi-continuous (Elias *et al.*, 2000), but fed-batch is the most frequently used method for recombinant protein production. As summarised in the dissertation by Kleist, substrate feeding can be controlled in three ways. First, substrate feeding can be controlled by monitoring directly measured variables such as dissolved oxygen or pH. While cells grow exponentially, the demand for oxygen is high and consequently, the pO<sub>2</sub> value low. When limiting substrate feed is used, the pO<sub>2</sub> value increases. In the same conditions, the pH value increases due to presence of ammonia and organic acid. The second way of controlling substrate feeding involves the determination of  $\mu$  (specific growth rate) and the third way is measuring limiting substrate concentration (Kleist, 2002). Batch cultivation brings certain limitations and following text brings a few points to be considered when using it.

To achieve an optimal growth and product yield, the medium composition is of major importance. For example, when using *leaky* strain *E. coli* JW1667-5 during batch cultivation for streptavidin production, SGA medium was shown not to be suitable, but variations of HSG medium were used instead (Müller *et al.*, 2016). When choosing a medium, it is important to remember that some nutrients can inhibit cell growth when present above certain a concentration. For example, glucose inhibits growth at concentration above 50 g/L, ammonia at concentration above 3 g/L and phosphorus at concentration above 10 g/L (Lee, 1996). Precipitation of media ingredients can affect downstream processing, purification operations and monitoring devices. Also, osmotic pressure and conductivity caused by high ion concentrations in the growth media may affect the membrane potential and activate different

stress mechanisms that induce reduction in growth rate (Shojaosadati *et al.*, 2008). Using complex media including yeast extract and peptone may decrease reproducibility because it can vary in composition.

Acetate formation in *E. coli* fermentations represents an important issue that is not to be neglected. It is produced when *E. coli* is grown under anaerobic or oxygen-limited conditions. However, *E. coli* cultures growing in the presence of excess glucose (concentrations above 2 g/L (Kleman and Strohl, 1994)) can also produce acetate even under aerobic conditions. High concentration of acetate, above 5 g/L at pH 7, reduces the growth rate and biomass yield (Kleist *et al.*, 2003). It is reported that acetate is not produced when glycerol is used as a carbon source. An adequate temperature should be chosen to enable cell growth as well as the production of desired product. Due to high viscosity, reduced mixing efficiency of the bioreactor is another physical limitation of HCDC and this problem intensifies with increasing bioreactor size (Lee, 1996). In high concentration zones cells may produce toxic by-products and in low concentration zones cells may be starved of substrate (Shojaosadati *et al.*, 2008). Mixing comes together with foaming, which is increased in HCDC due to increased cell lysis, which means higher protein concentration in the medium.

Another important issue are the induction time and the inductor itself. *lac* based promoters are still the first choice to be used in HCDC but IPTG could be replaced by lactose in the future, as it is less expensive and can be used as an additional carbon source (Shojaosadati *et al.*, 2008). In his paper, Studier developed a concept of auto-induction. The principle of auto-induction in this kind of media uses a mixture of glucose, lactose and glycerol in an optimized blend. Glucose is the preferred carbon source and is metabolized preferentially during growth, which prevents uptake of lactose until glucose is depleted, usually in mid to late log phase. Consumption of glycerol and lactose follows, the lactose being also the inducer of *lac*-controlled protein expression. In this way, biomass monitoring for timely inducer addition is avoided, as well as culture manipulation. Important fact to be considered is that expression strains suitable for auto-induction must have functional transporters for the appropriate sugar. Auto-induction is potentially applicable for any expression system having an inducer that is subject to this type of regulation. Because of that, IPTG is not suitable for use in auto-induction because it can enter the cell and induce expression without a specific transporter, and cultures cannot grow uninduced in the presence of IPTG (Studier, 2005, 2014).

Increasing concentration of IPTG does not necessarily increase productivity. The level of inducer required for optimal expression depends on the strength of the promoter, the presence or absence of repressor genes on a plasmid, the cellular location of the product, the response of the cell to recombinant protein expression, and the solubility of the target protein and the characteristics of the protein (Cserjan-Puschmann *et al.*, 2002). In the publication by Vidal *et al.* is shown that growth and enzyme production rates decrease by increasing the IPTG concentration in batch and fed-batch strategies up to the range of 200 to 1500  $\mu\text{mol IPTG/L}$ . Also, working in fed-batch, batch and shake flask cultures at the same IPTG concentrations gives the same level of specific activity. (Vidal *et al.*, 2005) Another important issue to be discussed is the induction time because the maximum yield of recombinant proteins in fermentations depend on the growth phase in which the expression is induced. For strains whose growth and/or viability are drastically reduced following induction, induction in late-logarithmic or stationary phase provides high cell densities for increased product formation, i.e. for growth decoupled production (Shojaosadati *et al.*, 2008). Ou *et al.* demonstrated that at stationary phase three *E. coli* systems they used induced with lactose, and one other induced with heat shock, could overexpress diversified genes, including three whose products are deleterious to the host cells, more stably and profitably than following the log phase induction protocol (Ou *et al.*, 2004).

Using *leaky* strains for recombinant protein production in batch cultivation can be more successful than using other way of extracellular recombinant protein production in batch cultivation. For example, when producing streptavidin during batch cultivation of *leaky* strain of *E. coli*, the maximal extracellular product concentration of  $2608 \pm 169$  nM was reached in the bioreactor after 40 h of cultivation. It surpasses the reference bioreactor concentration of 1600 nM when producing streptavidin in *E. coli* using BRP in batch cultivation by a factor of 1.63. (Miksch *et al.*, 2008; Müller *et al.*, 2016) Chen *et al.* used single and double knock-out *leaky* strains of *E. coli* for production of recombinant protein Trx-hPTH (human parathyroid hormone 1–84 coupled with thioredoxin as a fusion partner) in batch cultivation. They suspected that the mutants with double deletion of the genes *mrcA*, *mrcB* (both encode the peptidoglycan synthetase), *pal* (gene encoding peptidoglycan-associated outer membrane lipoprotein) and *lpp* (encoding for Braun's lipoprotein) may result in higher secretory levels of proteins than the mutants with single gene deletion. The extracellular yields of the target protein from mutants *lpp mrcB-pth*, *mrcA lpp-pth*, *mrcA pal-pth* and *mrcB pal-pth* with double-gene deletion are higher than that from mutant *lpp pal-pth*, suggesting that the deletion mutants of double genes associated with the biosynthesis of outer membrane and cell wall may be more

suitable for the extracellular production of target proteins than the deletion mutants of double genes associated with the biosynthesis of outer membrane only. Secretory level of target protein was up to 88.9 % when using *mrcA lpp-pth* compared to 71.1 % when using single knock-out strain *lpp-pth*, which confirms previously mentioned suspicion (Chen *et al.*, 2014).

### 3. MATERIALS AND METHODS

#### 3.1. Chemicals

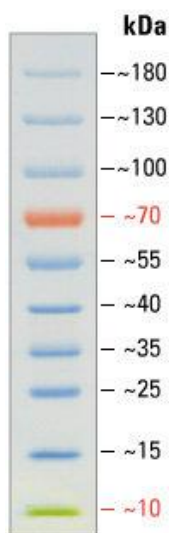
Following table (Table 1.) lists all used chemicals and their manufacturers. In Table 2., there is a list of special chemicals – kits and ladders (Figure 1.). Chemicals are dissolved in ddH<sub>2</sub>O except for 4-Nitrophenyl phosphate disodium salt hexahydrate, which is dissolved in glycine-HCl buffer made as explained later in chapter *Enzyme activity test*.

**Table 1.** List of used chemicals and their manufacturers.

<b>Chemicals</b>	<b>manufacturer</b>
4-Nitrophenol	Sigma-Aldrich Chemie GmbH
4-Nitrophenyl phosphate disodium salt hexahydrate	Sigma-Aldrich Chemie GmbH
agar – agar	Carl Roth GmbH + Co. KG
ammonium persulphate	Carl Roth GmbH + Co. KG
Bis-/Acrylamide (0,8 %, 30 %)	Carl Roth GmbH + Co. KG
bromophenol blue	Carl Roth GmbH + Co. KG
BSA (albumin fraction V)	Carl Roth GmbH + Co. KG
Coomassie Brilliant Blue G – 250	Carl Roth GmbH + Co. KG
dipotassium phosphate	VWR International GmbH
glycerine (99,5 %)	Emery Oleochemicals GmbH
Glycine	Carl Roth GmbH + Co. KG
IPTG	Carl Roth GmbH + Co. KG
Isopropanol	VWR International GmbH
kanamycin sulphate	Carl Roth GmbH + Co. KG
sodium carbonate	Carl Roth GmbH + Co. KG
sodium chloride	Fisher Scientific GmbH
sodium hydroxide	Carl Roth GmbH + Co. KG
phosphoric acid	Carl Roth GmbH + Co. KG
Pluronic (antifoam)	BASF SE
potassium dihydrogen phosphate	VWR International GmbH
SDS	Carl Roth GmbH + Co. KG
soya peptone	UD Chemie GmbH
TEMED	Carl Roth GmbH + Co. KG
Tris	Fisher Scientific GmbH
yeast extract	Ohly GmbH

**Table 2.** Special chemicals and their manufacturers.

<b>Chemical</b>	<b>manufacturer</b>
PageRuler Prestained Ladder	Thermo Fisher Scientific Inc.
Roti®–Nanoquant kit for protein concentration test K880	Carl Roth GmbH + CO. KG



**Figure 7.** PageRuler Prestained Ladder by Thermo Fisher Scientific Inc. on SDS electrophoresis gel. ([www.thermofisher.com/ordercatalog/product/26616](http://www.thermofisher.com/ordercatalog/product/26616), access date September 5, 2017)

### 3.2. Devices and lab consumables

Tables in this chapter show list of all used devices, their model and manufacturer, as well as lab consumables and their manufacturers.

**Table 3.** List of used devices with respective model and manufacturer.

<b>Device</b>	<b>Model</b>	<b>manufacturer</b>
Autoclave	V – 150 D – 65	Systemec GmbH
heat block	Blockthermostat BT 100	Kleinfeld Labortechnik GmbH
light microscope	BX40	Olympus Corporation
magnet mixer	IKAMAG REO	IKA
pH – meter	691	Metrohm AG



Shaker	Lab – Shaker LS – X	Kühner AG
spectrophotometer	BioPhotometer	Eppendorf AG
spectrophotometer (microplates)	SPECTRA MAX 250	Molecular Devices Corporation
ultrasound homogenizer	Sonifier 450	BRANSON
Vortex	Vortex – Genie 2	Scientific Industries, Inc.
Centrifuges	3-30KS 1-15	Sigma Laborzentrifugen GmbH
orbital rocking shaker	POLYMAX 2040	Heidolph Instruments GmbH and Co. KG
electrophoresis power supplier	Standard Power Pack P25	Biometra GmbH
analytical balance	PM34-K DeltaRange	Mettler – Toledo GmbH
agarose gel electrophoresis system	MINI GEL II	VWR International GmbH
precision balance	AE 260 DeltaRange	Mettler – Toledo GmbH
Freezer	MDF – U5386S	SANYO Electric CO., Ltd
vacuum dryer	VT 5042 EK	Heraeus

**Table 4.** List of used lab consumables and their manufacturers.

<b>Item</b>	<b>manufacturer</b>
BRANDplates® (96–well microplates), polystyrene: 350 µL	Brand GmbH + Co. KG
cuvette, polystyrene, 1.5 mL	Brand GmbH + Co. KG
pipette tips, polypropylene: 1000, 200 and 10 µL	Greiner Bio-One AG
microcentrifuge tube, polypropylene: 1,5 mL and 2 mL	Greiner Bio-One AG
Erlenmeyer flask with baffles, glass: 300 ml, 500 mL and 1000 mL	Schott Duran
Erlenmeyer flask, glass: 300 mL	Schott Duran
conical centrifuge tubes, polypropylene: 15 mL and 50 mL	Greiner Bio-One AG

### 3.3. Software

Table 5. below shows list of software used in this thesis.

**Table 5.** List of used software and respective developer companies.

Name	developer company
SoftMax® Pro	Molecular Devices Corporation
BiOSCADA Lab	BIOENGINEERING

### 3.4. Growth media

In this thesis, two different media were used: LB medium (*Luria – Bertani*) to grow a preculture and make glycerine cultures, and TB medium (*Terrific broth*) to grow main culture in flasks as well for the cultivation of bacteria in the bioreactor (Table 5. and 6.). If needed, kanamycin was added to a final concentration of 50 µg/mL. Media were sterilized in autoclave in 121 °C and pressure of 1 bar.

**Table 6.** Composition of *Luria-Bertani* medium, pH 7,4.

Component	concentration [g/L]
soya peptone	10
yeast extract	5
sodium chloride	10

\*to make agar plates, 15 g/L agar-agar added

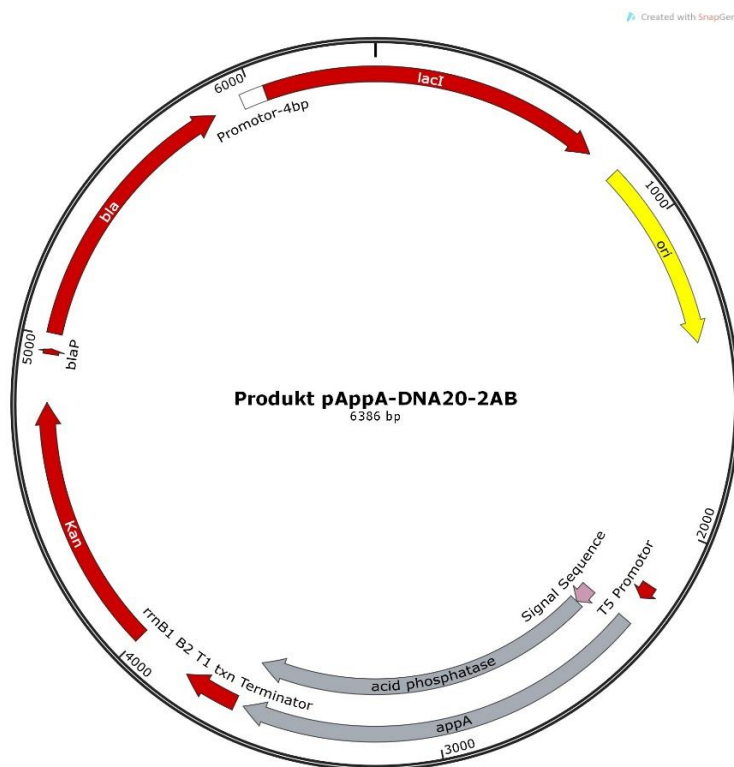
**Table 7.** Composition of *Terrific broth* medium

Component	concentration [g/L]
soya peptone	12,0
yeast extract	24,0
Glycerine	5,0
dipotassium phosphate, K <sub>2</sub> HPO <sub>4</sub> *	12,5
potassium dihydrogen phosphate, KH <sub>2</sub> PO <sub>4</sub> *	2,4

\* autoclaved separately from other components

### 3.5. Plasmid

In this paper plasmid pAppA-DNA20-2AB was used and later in text abbreviated as pAppA1. Figure 2. below shows plasmid map which contains all important features closely explained in Table 8.



**Figure 8.** Map of plasmid pAppA1 made with SnapGene software, GSL Biotech LLC.

**Table 5.** Explanation of abbreviations on plasmid map showed on Figure 2. above.

Contractions	meaning
<i>AppA</i>	phytase AppA from E. coli with native signal sequence for translocation
<i>Bla</i>	ampicillin resistance with promoter <i>blaP</i>
<i>Kan</i>	kanamycin resistance
<i>lacI</i>	repressor for binding to lac-operator
<i>ori</i>	high copy origin of replication, ColE1/pMB1/pBR332/pUC
T5 promoter	promoter induced by IPTG
rrnB1 T1 txn terminator	structural terminator

### 3.6. Bacterial strains

In Table 9. below, there is a list of *E. coli* strains used for this thesis. Each of them is transformed with previously explained plasmid pAppA1.

**Table 6.** List of bacterial strains with respective genotype and number used in Working Group Fermentation technology laboratory. Strains (except of strain W3110) are originally from KEIO collection and deletions written in column “strain” were made in Laboratory for Fermentation Technology.

strain	genotype	WG Fermentation Technology number
<i>E. coli</i> W3110	<i>F</i> <sup>-</sup> , $\lambda$ , <i>IN(rrnD-rrnE)</i> 1, <i>rph-10</i> (CGSC)	109 pAppA1
<i>E. coli</i> JW1667-5 <i>ΔkanR</i>	<i>F</i> <sup>-</sup> , <i>Δ(araD-araB)567</i> , <i>ΔlacZ4787(::rrnB-3)</i> , $\lambda$ , <i>Δlpp-752::kan</i> , <i>rph-1</i> , <i>Δ(rhaD-rhaB)568</i> , <i>hsdR514 ΔkanR</i> (CGSC)	808 pAppA1
<i>E. coli</i> JW 0940-6 <i>ΔompC ΔkanR</i>	<i>F</i> <sup>-</sup> , <i>Δ(araD-araB)567</i> , <i>ΔlacZ4787(::rrnB-3)</i> , $\lambda$ , <i>rph-1</i> , <i>Δ(rhaD-rhaB)568</i> , <i>hsdR514 ΔompA ΔompC ΔkanR</i>	918 pAppA1
<i>E. coli</i> JW 5780-1 <i>ΔyghH ΔkanR</i>	<i>F</i> <sup>-</sup> , <i>Δ(araD-araB)567</i> , <i>ΔlacZ4787(::rrnB-3)</i> , $\lambda$ , <i>rph-1</i> , <i>Δ(rhaD-rhaB)568</i> , <i>hsdR514 ΔfimD ΔyghH ΔkanR</i>	941 pAppA1

### 3.7. Methods

#### 3.7.1. Preculture setting

To grow preculture, 50  $\mu$ L of glycerine culture was added to 30 mL of LB medium (composition described in chapter Growth media) and grown in 300 mL flasks without baffles. Preculture used for bioreactor cultivation is grown in 100 mL of LB medium in 1 L flasks with baffles. Also, kanamycin is added in final concentration of 50  $\mu$ g/mL. Preculture was cultivated on shaker (120 rpm, 50 mm rotation radius) for 16 hours on 37° C.

#### 3.7.2. Strain stock

To keep bacterial culture over longer time, 800  $\mu$ L of preculture was added to 200  $\mu$ L of 87 % glycerine in a 1,5-mL reaction vessel. Then, the sample was mixed on vortex and frozen in

liquid nitrogen. Glycerine culture was kept in  $-80^{\circ}\text{C}$ . Short time storage of samples to be analysed was in  $-20^{\circ}\text{C}$ . Agar plates were stored in  $-4^{\circ}\text{C}$ .

### **3.7.3. Flask cultivation**

To set a main culture, in 300 mL Erlenmeyer flask with four baffles, 30 mL of TB medium was added. Also, kanamycin was added in final concentration of  $50\ \mu\text{g/mL}$ . Volume of inoculum, i.e. preculture, was calculated to set the initial  $\text{OD}_{600}$  value to 0.2. Cultivation was performed on a shaker (120 rpm, 50 mm rotation radius) at  $37^{\circ}\text{C}$  until  $\text{OD}_{600}$  reached a value between 0.8 and 0.9. At this point, IPTG as inductor was added to a final concentration of 1 mM. Samples from each of three biological replicates were taken at three time points: 0 hours (immediately after induction), 4 hours and 8 hours after induction.  $500\ \mu\text{L}$ - samples were taken in each time point for measuring  $\text{OD}_{600}$ , plasmid stability test and microscopy control.

To get supernatant samples,  $500\ \mu\text{L}$  from each biological replicate was taken and centrifuged for 10 minutes at  $4^{\circ}\text{C}$  and 7000 g. Supernatant samples were stored at  $-20^{\circ}\text{C}$ .

Also, 1 mL of cell culture from each biological replicate was taken and stored at  $-20^{\circ}\text{C}$  for later sonication, determination of total protein concentration and enzyme activity in cell lysate.

### **3.7.4. Bioreactor cultivation**

Selected strains were cultivated in a bioreactor. Two fermentations were performed per strain. The purpose of the first fermentation was to determine the time point at which the culture enters the stationary phase in order to induce protein expression during the second fermentation at the determined time point. TB medium was used as a nutrient medium (composition in chapter *Materials*) to which, after sterilization, antibiotic kanamycin was added to final concentration of  $50\ \mu\text{g/mL}$ . Additionally, in the second fermentation inductor IPTG was added to final concentration of 1 mM at the previously determined time point. The software BiOSCADA Lab by BiOENGINEERING was used to follow the course of fermentation and collect process data.

The double knock-out *E. coli* strain  $\Delta ompA\ \Delta ompC\ \Delta kanR$  was cultivated in bioreactor NLF 3. The total volume of the bioreactor was 7 L while the working volume was 5 L. Two parallel cultivations of the single knock-out strain  $\Delta lpp\ \Delta kanR$  were done in two equal bioreactors, NLF 1 and NLF 2. The total volume of bioreactors was 19 L while the working volume was 12 L. Conditions of cultivation are shown in Table 10. below.

**Table 10.** *Conditions of cultivation in bioreactors.*

<b>Conditions</b>	<b>bioreactor</b>	
	NLF 1 and NLF2	NLF 3
<b>pH</b>	7.4	7.4
<b>Temperature</b>	37° C	37° C
<b>Overpressure</b>	0.2 bar	0.2 bar
<b>air flow</b>	12 NL/m	5 NL/m
<b>pO<sub>2</sub></b>	60 %	60 %
<b>stirrer speed</b>	200-1500 rpm	200-1500 rpm

To keep a constant pH during fermentations, 10 % phosphoric acid and 2 M NaOH are used and sterilized prior to use as well as antifoam Pluronic

A stirrer cascade is used to control oxygen concentration in nutrient medium. The lower limit was 200 rpm (*rotations per minute*) and the upper one 1500 rpm. pO<sub>2</sub> signal is adjusting pO<sub>2</sub> level and if the level is lower than the setpoint, the pO<sub>2</sub> control-unit gives a signal to the stirrer control unit to increase the stirrer frequency.

Cell growth was monitored by measuring optical density. Initial cell density was 0.2. Samples were taken every hour by autosampler. After induction, samples were taken at six time points. First sample was taken right after the induction and others one, two, four, six and eight hours after the induction. Samples were taken aseptically using a steam-sterilisable sampling valve of bioreactor and prepared in a same way as described in chapter *Flask cultivation*.

Bioreactor specification is attached in *Appendix*.

### **3.7.5. Cell lysis**

Sonication is used to lyse bacterial cells in following way: 1 mL of defrosted sample (taken at each time point) was put in an ice-water bath and sonicated in three cycles for 30 seconds with 30 seconds break in between the cycles. Ultrasound homogeniser settings were: *Timer on hold*, *Duty Cycle on constant* and *Output Control* was set on 2. The efficiency of sonication is monitored by microscopy. If cells were not disrupted, another cycle of sonication is repeated. Then, samples were centrifuged for 10 minutes on 4 ° C and 16000 g. The precipitate was discarded, and the supernatant was kept on -20 ° C.

### **3.8. Analytical methods**

#### **3.8.1. Optical density measurement**

During the cultivation, bacterial growth was monitored by measuring optical density (OD<sub>600</sub>). Using photometer (BioPhotometer by Eppendorf AG), absorbance is measured on wavelength of 600 nm. To stay in linear range (0 – 0.9), samples are diluted with respective medium in disposable polystyrene cuvette (1.5 mL, Brand GmbH & Co. KG) prior to measurement. Respective medium was used as a blank.

#### **3.8.2. Microscopy**

A few drops of cell suspension were diluted on a slide and observed under BX40 light microscope by Olympus Corporation with magnification 200x. Sample photos were taken and saved using IC Capture 2.0 software by Imaging Source Europe GmbH.

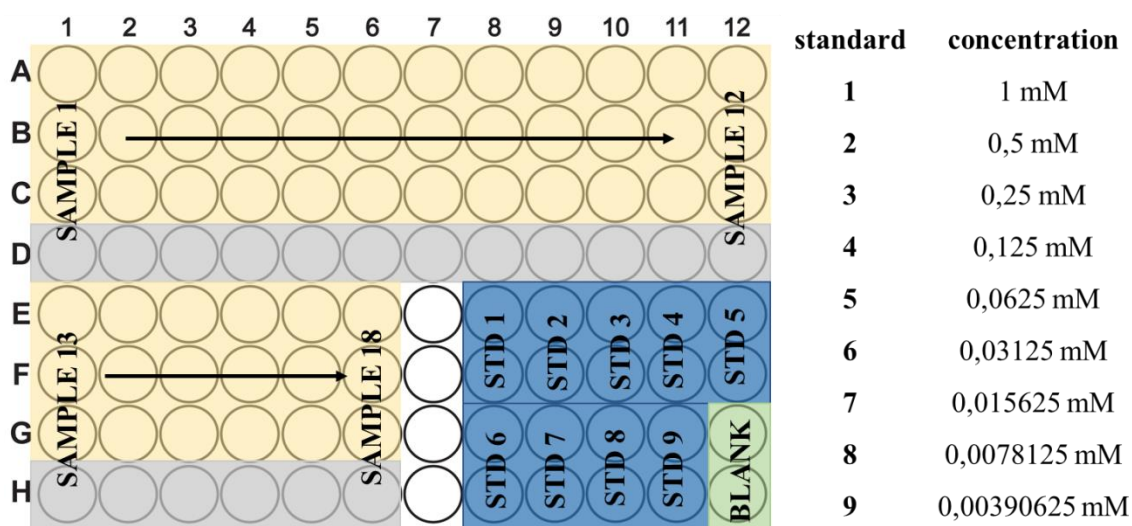
#### **3.8.3. Plasmid stability test**

100 µL-samples taken from each biological replicate were pooled in a common reaction vessel and diluted to final concentration of  $1 \times 10^{-4}$ ,  $1 \times 10^{-5}$  and  $1 \times 10^{-6}$  (to have single cell colonies) and grown on LB agar plates in 37 °C, overnight. Afterwards, single colonies were picked and cultivated on two LB agar plates: one without kanamycin and one with kanamycin (50 µg/mL). The test was done for samples at each time point. The number of colonies per plate is 50. Cultivation was overnight in 37 °C. Plasmid stability is calculated as a ratio of the number of bacterial colonies grown on LB plate with antibiotic and the number of bacterial colonies grown on LB plate without antibiotic.

#### **3.8.4. Enzyme activity test**

Acid phosphatase activity test with *pNPP* (*para*-nitrophenylphosphate) is used to quantify the enzyme activity in both supernatant and total enzyme activity (in cell lysate and supernatant together). Samples and standards are diluted in fresh 0.25 M glycine–HCl buffer, pH 2.5. Supernatants are diluted in a range of 1:5 to 1:120 and disrupted cell samples in a range of 1:35 to 1:1100.

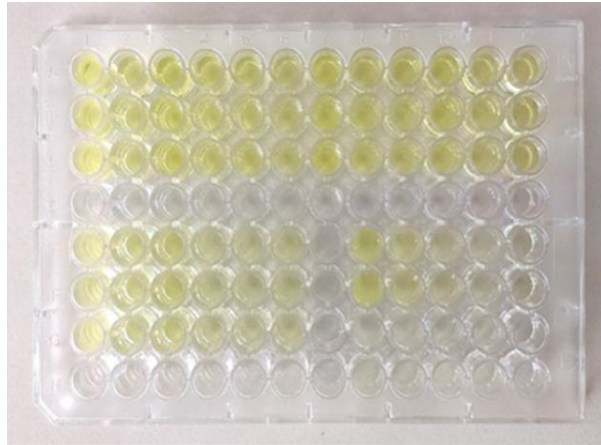
Pipetting schedule in 96-well plate is shown on Figure 4. below.



**Figure 9.** Pipetting schedule for enzyme activity test. Yellow colour stands for samples (pipetted in three replicates) in which substrate was added, grey colour stands for samples in which buffer was added instead of substrate, blue colour stands for standards and green colour for blank (buffer only), both pipetted in two replicates. On the right side, there are concentrations of standard para-nitrophenol.

50  $\mu$ L of samples and standards was pipetted in a 96-well plate and incubated in a thermostat in 50  $^{\circ}$ C for exact 15 minutes as well as the substrate solution, 50 mM para-nitrophenylphosphate (pNPP) dissolved in 0.25 M glycine-HCl buffer. After 15 minutes of incubation, 50  $\mu$ L of substrate or buffer is added to samples and standards (see figure above). The reaction is stopped after 10 minutes by adding 100  $\mu$ L of stop solution (1 M sodium carbonate) in each well, causing a change of colour from colourless to yellow. Thereafter,  $A_{405}$  was measured using software SoftMax<sup>®</sup> Pro. Absorbance value of blank (green coloured wells, Figure 4.) is subtracted from measured absorbance values of samples and standards. This step eliminates influence of buffer. To eliminate autocatalysis influence, absorbance value measured in grey wells (Figure 4.) is subtracted from absorbance values of respective samples. Enzyme activity is calculated from standard curve which correlates  $A_{405}$  of standards and concentration of product pNP. Targeted  $A_{405}$  measuring range was from 0.75-1.1 because in this narrow range, correlation of product concentration and absorbance is linear. One unit (U) corresponds to 1 mM of product (pNP) per minute.



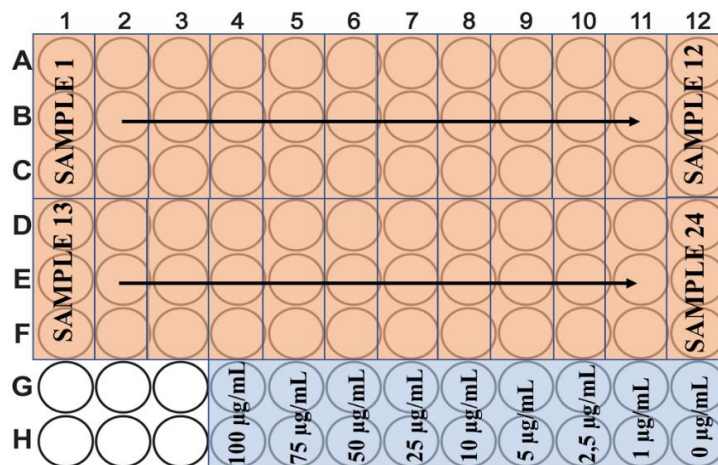


**Figure 10.** Samples change colour from colourless to yellow after adding stop solution.

### 3.8.5. Total protein quantitation – modified Bradford’s protein assay

Prior to the measurement samples were diluted in H<sub>2</sub>O<sub>dd</sub> - supernatants were diluted in a range of 1:5 to 1:20 and cell lysate samples in a range of 1:15 to 1:250. According to the schedule (Figure 6.), 50 µL of each calibration standard and 50 µL of the sample dilutions were pipetted into the wells of a 96-well plate. Standards were pipetted in two replicates and samples in three technical replicates. BSA (*bovine serum albumin*) was used as standard.

Roti®–Nanoquant solution (5 x) was diluted in 4 volumes of H<sub>2</sub>O<sub>dd</sub> and 200 µL of 1 x solution was pipetted to the standards and the samples on plate. The plate was incubated for 5 minutes at room temperature. Thereafter, OD<sub>590</sub> and OD<sub>450</sub> were measured using software SoftMax® Pro. To calculate the protein concentration, the quotient OD<sub>590</sub>/OD<sub>450</sub> of each sample was compared to the calibration curve (dependence of OD<sub>590</sub>/OD<sub>450</sub> to protein concentration).



**Figure 11.** Pipetting schedule for total protein test: orange colour stands for samples (pipetted in three replicates) and blue colour represents standards (pipetted in two replicates).

### 3.8.6. SDS – PAGE

Protein samples (prepared in 4 x Laemmli buffer followed by boiling at 96°C for 5 min) were separated on SDS-PAGE gels. Polyacrylamide gels are composed of a separating and a stacking gel (Table 10.). First, the separation gel was poured and layered with isopropanol. It was polymerizing for 30 min at room temperature. Thereafter, isopropanol was removed, the stacking gel was poured, and a comb was inserted into the layer of stacking gel solution. It was left for 10 min to polymerize. Afterwards, the comb was removed, the gel was placed in the electrophoresis apparatus and filled with 1 x electrophoresis buffer. 8 µL of pre-stained marker and 20 µL of prepared samples were loaded and electrophoresis was performed at the current of 20 mA for the stacking gel and of 40 mA for the separation gel. Electrophoresis is tracked by stain migration and stopped when stain reached the bottom of the plate. Gels were stained in Comassie brilliant blue solution (Table 11.) and destained in water. Both staining and destaining was performed on orbital rocking shaker. Composition of each gel and other used solutions is listed in tables below.

*Table 11. Composition of polyacrylamide separating and stacking gel.*

	separating gel (12,5%)	stacking gel (5%)
H <sub>2</sub> O	1,5 mL	775 µL
1 M Tris – HCl, pH 8,8	2,8 mL	-
0,25 M Tris – HCl, pH 6,8	-	1,25 mL
Bis/Acrylamide (0,8%, 30%)	3,0 mL	425 µL
5% SDS	150 µL	50 µL
10% APS	37,5 µL	25 µL
TEMED	2,5 µL	2,5 µL

**Table 12.** *Composition of buffers and stain solution used for SDS-PAGE.*

<b>Solution</b>	<b>Component</b>	<b>concentration</b>
<b>4 x Laemmli buffer, pH 6,8</b>	bromphenol blue	200 mg/L
	dithiothreitol	200 mM
	Glycerine	200 g/L
	SDS	40 g/L
	Tris-HCl	100 mM
<b>stain solution</b>	80% <i>o</i> -phosphoric acid	2 % (v/v)
	ammonium sulphate	50 g/L
	Coomassie brilliant blue G-250	200 mg/L
	ethanol	10 % (v/v)
<b>Tris-glycine electrophoresis buffer, pH 8,3</b>	Glycine	192 mM
	SDS	1 g/L
	Tris	25 mM

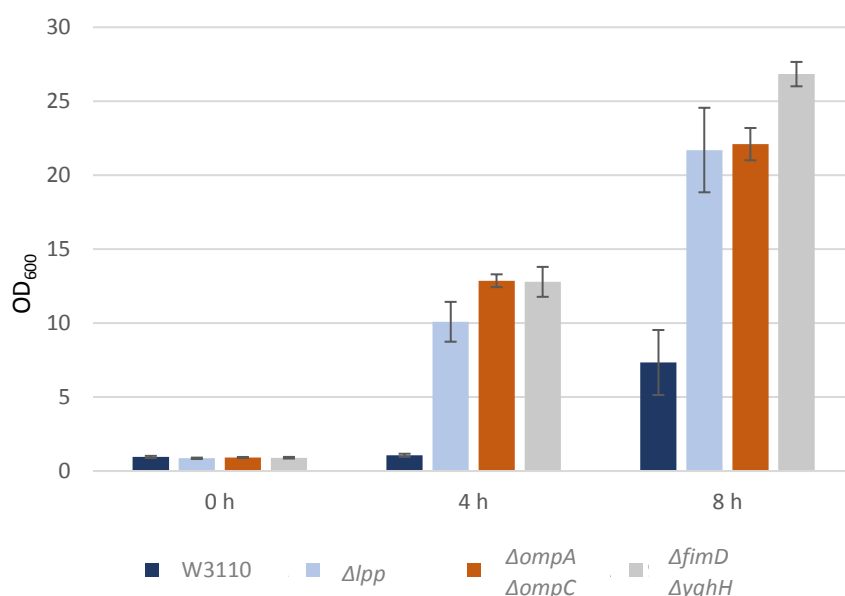
## 4. RESULTS AND DISCUSSION

### 4.1. Flask cultivation of different *E. coli* strains

This chapter contains results obtained during flask cultivations of four different *E. coli* strains (Table 9). The aim of the flask cultivation was to see how certain deletions of the selected strains influence the cell growth, protein production and secretion. The secretion ability of the cultivated strains was compared, and based on the obtained results, strains with the best secretion ability were selected to be cultivated in larger scale, i. e. in bioreactors. Each of the strains has also kanamycin resistance, i. e.  $\Delta kan$  mutation. To make a legend on the charts shorter and easier to follow, pAppA1 plasmid, in text added to the strain names, is left out.

#### 4.1.1. Growth behaviour and OD<sub>600</sub>

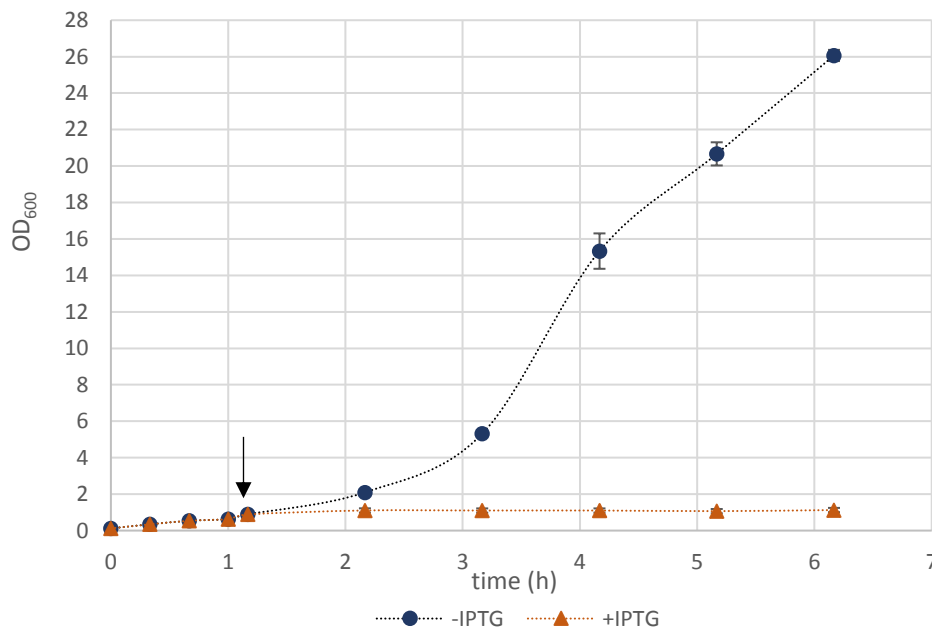
Figure 12 shows the OD<sub>600</sub> measured at three different time points – 0 h (right after induction), 4 h (four hours after induction) and 8 h (eight hours after induction).



**Figure 12.** Optical density of bacterial cultures measured after induction.  $N = 3 \times 3$ .

It can be noticed that strain *E. coli* W3110 had the smallest cell density at both four and eight hours after induction reaching a maximal OD<sub>600</sub> 7.33. The strains *E. coli*  $\Delta lpp$  pAppA1 and *E. coli*  $\Delta ompA \Delta ompC$  pAppA1 reached similar OD<sub>600</sub> both in fourth and eighth hour after induction and maximal value was about 22. Strain  $\Delta fimD \Delta yghH$  pAppA1 reached highest

OD<sub>600</sub> of all strains in eighth hour after induction and it was  $26.83 \pm 0.83$ . In accordance with the cell density of *E. coli* W3110 pAppA1, total protein concentration was the lowest for this strain in supernatant and in cell lysate samples in comparison to other strains (Table 15). The same can be seen on SDS-PAGE gel – protein band which represents phytase is barely visible in line of supernatant both for fourth and eighth hour after induction (Figure 17). The cell density of *E. coli* W3110 pAppA1 was increasing noticeably less than the cell density of other strains after moment of induction until fourth hour after induction. To check if this is reproducible, cells of strain *E. coli* W3110 pAppA1 were cultivated with and without induction. Preculture was made in 50 mL LB medium with 50 µL/mg kanamycin and 50 µL of glycerine culture. Main culture was cultivated in TB medium with 50 µL/mg kanamycin and initial OD<sub>600</sub> 0.2. Prior to induction, half of the cell culture volume was separated in other flask where IPTG was added in final concentration of 1 mM. At Figure 13., one can see the difference clearly: in flask without added IPTG, cells grow normally following standard growth curve, while after induction, cell growth stagnates - OD<sub>600</sub> value is about 1. This demonstrates that adding IPTG causes cell stress which is reflected in lower cell density in first four hours after the induction (Dvorak *et al.*, 2015).



**Figure 13.** Growth curve of strain *E. coli* W3110. The moment of induction is pointed with an arrow. Black curve stands for culture without added inductor while orange curve stands for culture induced with IPTG. *N* = 3.

#### 4.1.2. Enzyme activity and percentage of secretion

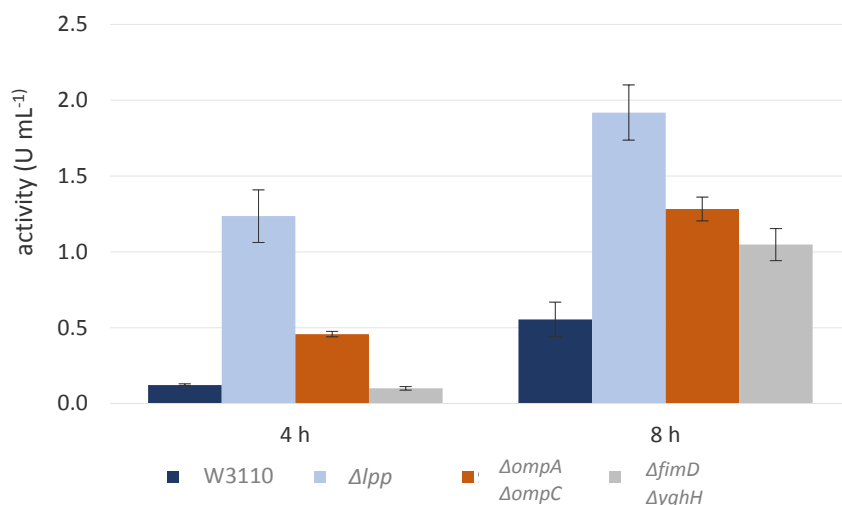
Table 13 contains the results of enzyme assay performed as described in the chapter Materials and methods. Enzyme activity in supernatants and in cell lysate of different strains are shown as total activity and as activity normalized to OD<sub>600</sub>.

**Table 13.** Enzyme assay and OD<sub>600</sub> results for tested *E. coli* strains

Strain	time after induction (h)	OD <sub>600</sub>	total enzyme activity (U mL <sup>-1</sup> )		normalized enzyme activity (U mL <sup>-1</sup> OD <sup>-1</sup> )	
			supernatant	cell lysate	supernatant	cell lysate
W3110	4	1.06 ± 0,11	0.12 ± 0,01	0.77 ± 0,09	0.11 ± 0,01	0.72 ± 0,07
pAppA1	8	7.33 ± 0,22	0.55 ± 0,11	1.22 ± 0,09	0.08 ± 0,02	0.17 ± 0,02
<i>Δlpp</i>	4	10.09 ± 1,35	1.24 ± 0,17	5.43 ± 1,02	0.13 ± 0,01	0.54 ± 0,08
pAppA1	8	21.70 ± 2,86	1.92 ± 0,18	12.82 ± 0,84	0.09 ± 0,01	0.59 ± 0,06
<i>ΔompA</i>	4	12.87 ± 0,43	0.46 ± 0,02	8.22 ± 1,45	0.04 ± 0,00	0.64 ± 0,14
<i>ΔompC</i>	8	22.10 ± 1,09	1.28 ± 0,08	51.30 ± 13,15	0.06 ± 0,00	2.31 ± 0,59
<i>ΔfimD</i>	4	12.79 ± 1,01	0.10 ± 0,01	6.76 ± 0,78	0.01 ± 0,00	0.53 ± 0,03
<i>ΔyghH</i>	8	26.83 ± 0,83	1.05 ± 0,11	17.71 ± 1,52	0.04 ± 0,00	0.66 ± 0,06

As can be seen in the table above, there are differences in the enzyme activity between the tested strains. The enzyme activity of the entire sample, i. e. cell lysate (supernatant and disrupted cells) provides information on the extent to which phytase was expressed. Strains W3110 pAppA1 and *Δlpp* pAppA1 show the highest total activity in cell lysate for both measuring points. After eight hours, the activity in the cell lysate of strain *ΔompA ΔompC* pAppA1 is four times higher than the activity in cell lysate of strain *Δlpp* pAppA1. High enzyme activity in supernatant indicates high protein secretion. The highest total activity at both measuring points in supernatant, can be noticed for strain *Δlpp* pAppA1 followed by strain *ΔompA ΔompC* pAppA1. The activity in supernatant of the latter strain at eighth hour is almost the same as activity at the fourth hour in supernatant sample of the strain *Δlpp* pAppA1 (Table 13). Because of that, strain *Δlpp* pAppA1 is suspected to have higher secretion ability (Shin and Chen, 2008) than strain *ΔompA ΔompC* pAppA1. The lowest activity in supernatant can

be seen for strain *E. coli* W3110 pAppA1, as expected, considering the lowest cell density and lowest total protein concentration (Table 15, Figure 14).



**Figure 14.** Comparison of enzyme activity in supernatants at fourth and eighth hour after induction.

To assess the strains regarding their suitability for extracellular phytase production, all considered elements must not be considered separately. The secreted fraction of phytase is an important indicator of the secretion ability. It represents the quotient of the enzyme activity in supernatant and the total enzyme activity in cell lysate. Table 14 lists the secreted fraction at each time point for each strain.

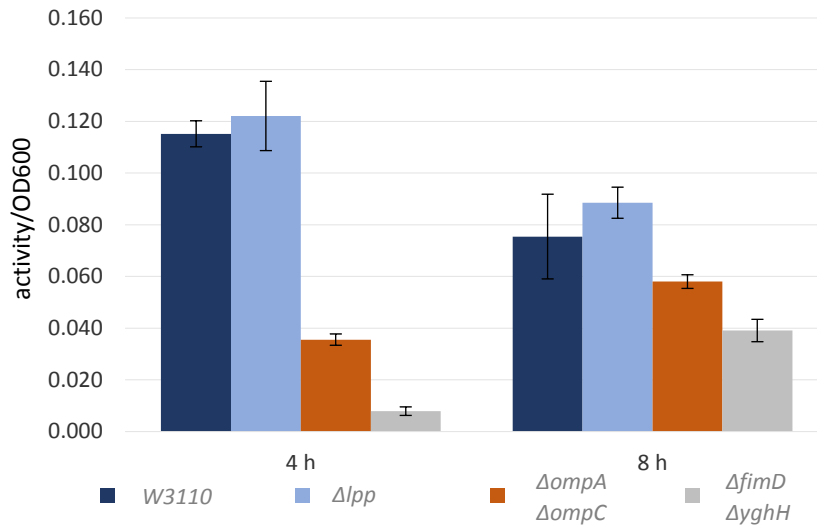
**Table 14.** Percentage of activity in supernatant of four different *E. coli* strains

	4 h	8h
W3110 pAppA1	15.97 %	45.43 %
$\Delta lpp$ pAppA1	22.74 %	14.97 %
$\Delta ompA \Delta ompC$ pAppA1	5.57 %	2.50 %
$\Delta fimD \Delta yghH$ pAppA1	1.48 %	5.92 %

Patent US20080254511 A1 by Wacker Chemie defines *leaky* cells as cells that after fermentation show a higher concentration of periplasmic proteins in the nutrient medium than the *E. coli* W3110 strain (ATCC 27325) under the same conditions (Dassler *et al.*, 2008). The strain W3110 is considered to be a wild type, i.e. it is K-12 derived strain. (Hayashi *et al.*,

2006). Considering that definition and obtained results, only  $\Delta lpp$  pAppA1 strain can be defined as *leaky* because percentage of activity in supernatant in fourth hour after induction is 22.74 %, what is higher than activity rate in supernatant of wild-type strain W3110. On the other hand, the percentage of activity in supernatant of  $\Delta lpp$  pAppA1 strain decreases over the time unlike increasing activity rate in the supernatant of W3110 strain. In second measuring point, wild-type strain shows the highest percentage of activity in supernatant of all tested strains although  $\Delta lpp$  pAppA1 strain is proven to release proteins into the nutrient medium very well (Shin and Chen, 2008). These results may be a consequence of the cell lysis which occurred after the induction. The slower cell growth of W3110 may indicate cell lysis and therefore it seems they leak more protein. High percentage of secreted protein produced by W3110 might be due to the low amount of the totally produced protein. This may be also due to some errors during enzyme activity test, although each enzyme activity test is performed the same way. The substrate solution is very sensitive to temperature leading to higher readings of absorbance if substrate is not well tempered or it is defrosted and frosted multiple times. Another problem is narrow range of linear dependency of absorbance and concentration (absorbance value should be in range from 0,7 -1,1). Because of the limited range, dilutions of samples sometimes needed to be high, which also affects error values. Furthermore, errors are high due to different cell growth in each of three biological replicates. Also, efficiency of sonication is not the same for every sample because there is no way to quantify how well cell disruption step is performed. The only way the disruption efficacy is checked is controlling them via microscopy. For some samples there have been multiple repetitions of sonication cycles which caused enzyme molecules more likely to denature. Because all of that, there are multiple criteria when it comes to decision which strain shows the best secretion ability. The  $OD_{600}$  must also be considered for further assessment of the strains. The lower the cell density, the lower is the number of cells that potentially secrete. The activity must therefore be normalized to the  $OD_{600}$ . This is shown in Table 13 and Figure 15.





**Figure 15.** Normalized activity comparison in supernatants of four different *E. coli* strains.

The bars represent the activity of phytase normalized to the OD<sub>600</sub> of the respective strain. The highest normalized activity in supernatant at fourth hour of cultivation can be noticed for strain  $\Delta lpp$  pAppA1. Second highest activity in the supernatant at fourth hour of cultivation is for the strain *E. coli* W3110 pAppA1, but it is important to accentuate that this strain showed lowest total activity and the lowest cell growth (Table 13). At fourth hour after the induction, normalized phytase activity in the supernatant of strain  $\Delta lpp$  pAppA1 is more than 3 x higher than the normalized activity of strain  $\Delta ompA \Delta ompC$  pAppA1 what is in accordance to total activity comparison in supernatant in same time point for the same strains. The lowest normalized activity in the supernatant at fourth hour is one of the strain  $\Delta fimD \Delta yghH$  pAppA1. In eighth hour, activity in the supernatant decreases for strains *E. coli* W3110 pAppA1 and  $\Delta lpp$  pAppA1 in comparison to the activity at fourth hour, but increases for strains  $\Delta ompA \Delta ompC$  pAppA1 for 1,6x and  $\Delta fimD \Delta yghH$  for almost 5x in a comparison to the activity at fourth hour after induction.

#### 4.1.3. Total protein production and secretion

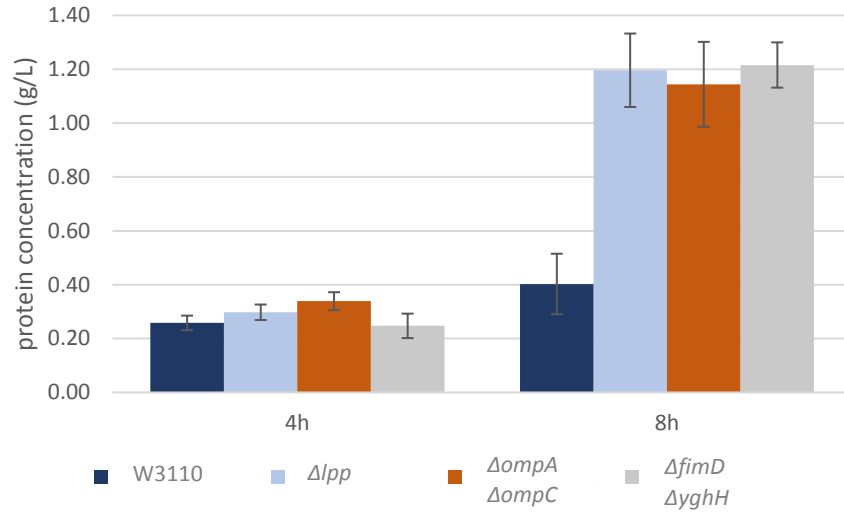
Besides the cell density and the enzyme activity, protein concentration in the supernatant and cell lysate was determined as well. Results of modified Bradford test described in chapter Materials and methods are shown in Table 15.

**Table 15.** Determined protein concentrations and OD<sub>600</sub> for four tested strains. N = 3 x 3.

strain	time	OD <sub>600</sub>	protein concentration (g L <sup>-1</sup> )	
			supernatant	cell lysate
W3110	4	1.06 ± 0,11	0,26 ± 0,03	0,903 ± 0,18
pAppA1	8	7.33 ± 0,22	0,40 ± 0,11	1,437 ± 0,19
<i>Δlpp</i> pAppA1	4	10.09 ± 1,35	0,29 ± 0,03	3,757 ± 0,22
	8	21.70 ± 2,86	1,20 ± 0,14	6,682 ± 0,86
<i>ΔompA ΔompC</i>	4	12.87 ± 0,43	0,34 ± 0,03	3,232 ± 0,30
pAppA1	8	22.10 ± 1,09	1,14 ± 0,16	6,199 ± 0,51
<i>ΔfimD ΔyghH</i>	4	12.79 ± 1,01	0,25 ± 0,05	3,475 ± 0,08
pAppA1	8	26.83 ± 0,83	1,22 ± 0,08	5,968 ± 0,51

Comparing results of activity in supernatant to protein concentration in supernatant, it can be seen there is no good correlation between them. It indicates that deletions of the genes for outer membrane protein cause an increase in secretion of periplasmic proteins into the medium, but secretion is not specific. Results listed in Table 15 show an increase in total protein concentration over time in both supernatant and cell lysate of all tested strains transformed with plasmid pAppA1. Further, a comparison of protein concentration in supernatants of tested strains is shown in Figure 16. After four hours, the highest protein concentration in supernatant is noticed for strain *ΔompA ΔompC* pAppA1. Eight hours after induction, the highest total protein concentration in supernatant is for strain *ΔfimD ΔyghH* pAppA1, and it is almost 5 times higher than in fourth hour after induction with IPTG. The similar can be noticed for the *Δlpp* strain too. Total protein concentration in cell lysate of the same strain in eighth hour after induction is 1,7 times higher than in fourth hour after induction. The highest total protein concentration in cell lysate is measured for strain *Δlpp* pAppA1 after eight hours and its high protein concentration in the cell lysate may indicate a good protein production ability.

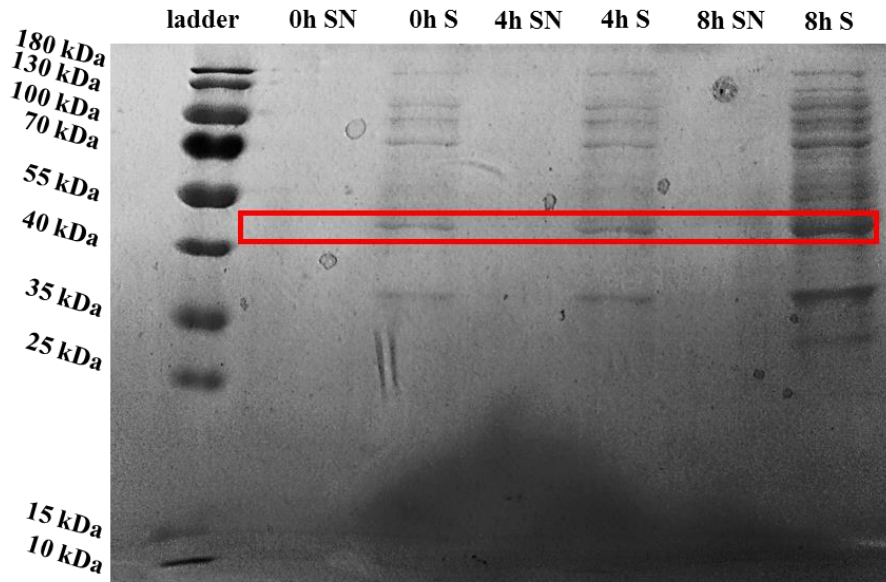
High protein concentration in supernatant indicates good secretion ability of different periplasmic proteins, but also, it can mean cell lysis.



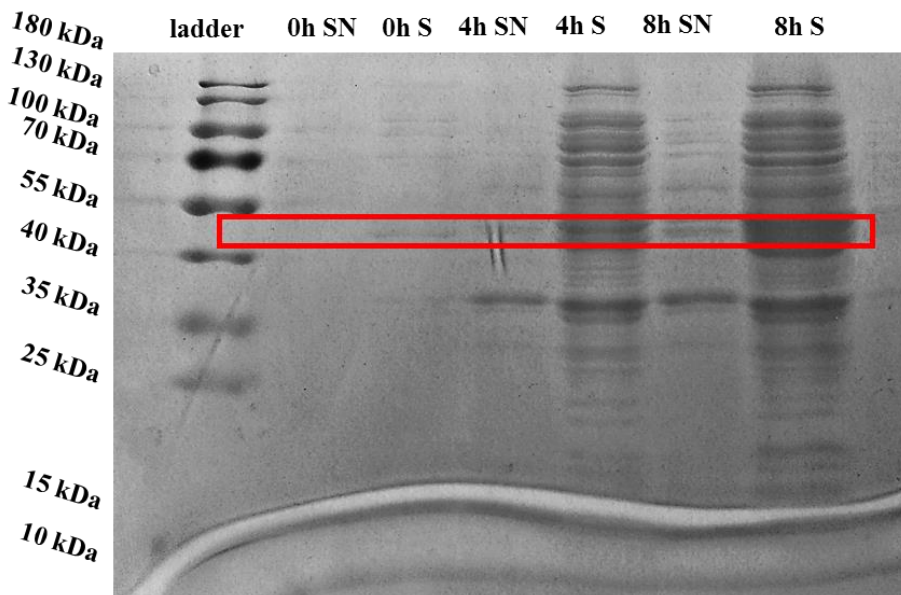
**Figure 16.** Protein concentration comparison in supernatants.  $N = 3 \times 3$ .

#### 4.1.4. SDS – PAGE

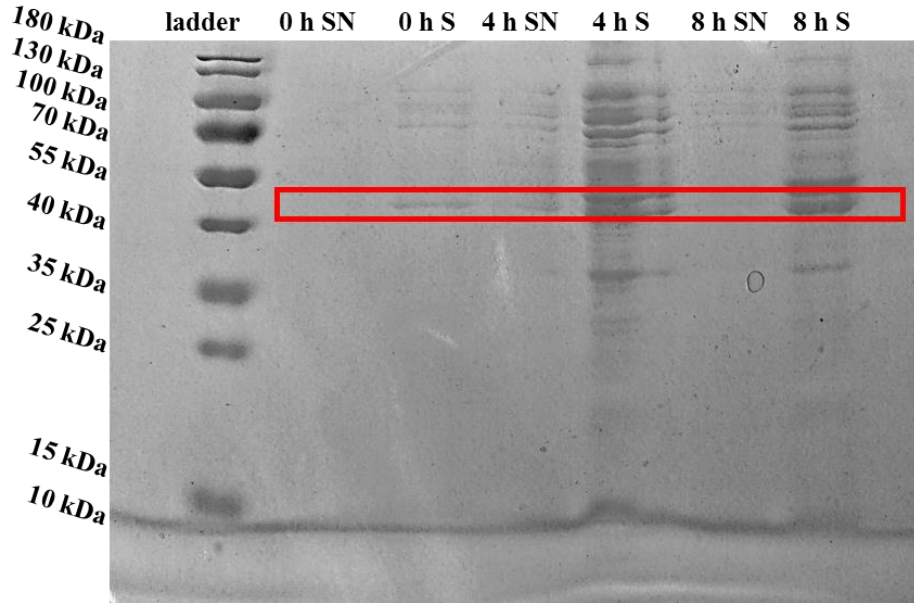
The following figures 17-20 are showing SDS-PAGEs of supernatant and total cell culture of the tested strains at two measuring time points, 4 h and 8 h. MW of phytase is expected to be around 45 kDa.



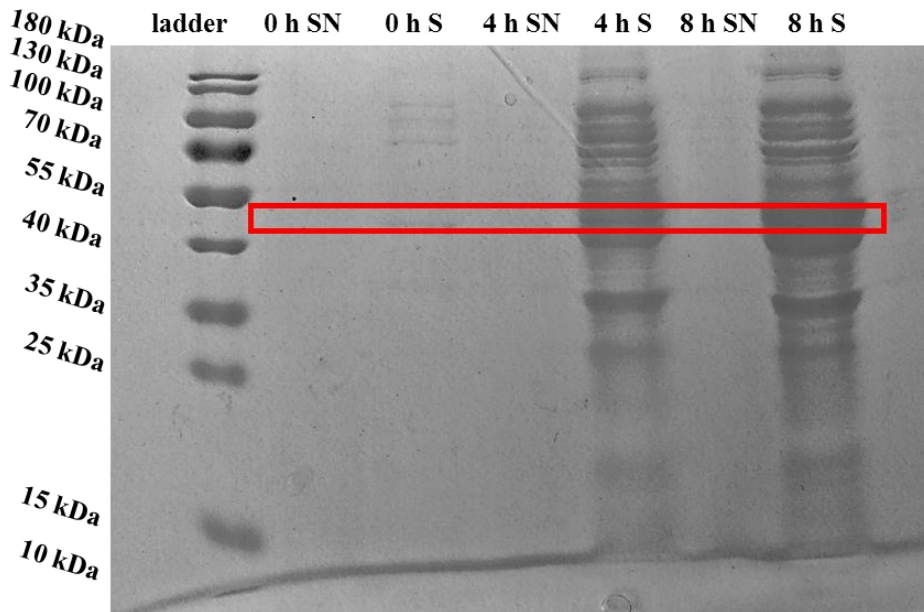
**Figure 17.** SDS-PAGE, *E. coli* strain W3110 pAppA1. 0h, 4h and 8h stand for time after induction samples were taken at. SN stands for supernatant and S for cell lysate and supernatant sample together. Red box shows phytase band.



**Figure 18.** SDS-PAGE, *E. coli* strain  $\Delta$ lpp pAppA1. 0h, 4h and 8h stand for time after induction samples were taken at. SN stands for supernatant and S for cell lysate and supernatant sample together. Red box shows phytase band.



**Figure 19.** SDS-PAGE, *E. coli* strain  $\Delta ompA \Delta ompC pAppA1$ . 0h, 4h and 8h stand for time after induction samples were taken at. SN stands for supernatant and S for cell cell lysate and supernatant sample together. Red box shows phytase band.



**Figure 20.** SDS-PAGE, *E. coli* strain  $\Delta fimD \Delta yghH pAppA1$ . 0h, 4h and 8h stand for time after induction samples were taken at. SN stands for supernatant and S for cell lysate and supernatant sample together. Red box shows phytase band.

SDS – PAGE can be an useful tool to assess to which extent the cell lysis occurred. Besides that, it can provide information whether there is a contamination with other proteins and it is also used as a confirmation that there is secreted target protein in the nutrient medium whose activity has been already detected before. Because of the features of the cell wall mutant strains, cells might be more prone to lysis. Weakened cell wall contributes to the cell sensitivity due to influences from the outer environment (Wang, 2002). An increased permeability of the cell wall is supposed to increase the secretion of the target protein, but it also enhances release of the other periplasmic proteins to the nutrient medium, leading to contamination. With the signal sequence being cleaved, protein AppA has molecular weight of approximately 45 kDa and protein band is visible in supernatant and cell lysate of almost all tested strains. In supernatant of the reference strain W3110, phytase band cannot be seen in sample taken at fourth hour but it is barely visible in supernatant sample taken eight hours after induction. In cell lysate, visibility of the phytase band on SDS-page increases over the time probably due to noticeable increase of cell density from 1.06 to 7.33 and not because of improved protein production (Figure 17). The absence of the phytase band, MW of 45 kDa, in supernatant sample of this strain might be due to too small total amount of produced protein.

In supernatant samples of strain *Δlpp* pAppA1, phytase band is visible for both samples taken four and eight hours after induction (Figure 18). Band is more distinct in supernatant sample taken at eighth hour what supports result of protein concentration test but does not support decreasing activity percentage in supernatant, again indicating error in enzyme activity test. Pale band, size about 47 kDa is visible in supernatant sample taken in eighth hour. It may represent phytase protein with signal sequence not being cleaved at the end of translocation. Besides AppA band, one other band, size about 37 kDa is also visible in supernatant samples on SDS-PAGE gel. It may be another, smaller, periplasmic protein that due to its size secretes more easily than phytase and causes contamination. Not only it is noticeable in supernatant samples, but also in cell lysate samples. Of all tested strains, supernatant samples taken for *Δlpp* pAppA1 strain show phytase band the clearest. Although enzyme activity in supernatant of *ΔompA ΔompC* pAppA1 strain taken in fourth hour was second highest, phytase band is poorly noticeable in respective sample on SDS-PAGE (Figure 19). Phytase band from the sample taken in following measuring point gets even less visible. In both samples, there are no apparent contaminating proteins indicating absence or a small level of cell lysis. On the other hand, phytase band is intensive in cell lysate samples of this strain. It can be interpreted as this strain is having good phytase production ability, but poor protein secretion ability.

Strain *ΔfimD ΔyghH* pAppA1 reached highest OD<sub>600</sub> value of all strains, which may lead to expectation of high phytase activity. On contrary, very low enzyme activity was detected in both supernatant and cell lysate samples. In supernatant sample taken in fourth hour after induction, phytase band on SDS-PAGE is barely visible and for following supernatant sample it is invisible (Figure 20). Due to high OD<sub>600</sub> values, protein bands were conspicuous in cell lysate samples. Interestingly, even though this strain showed no phytase band on SDS-page, there were no evidence of contamination with smaller proteins too. It may indicate that mutations in these specific genes encoding cell wall proteins do not increase protein secretion at all.

#### 4.1.5. Plasmid stability

In previous experiments done in the Laboratory of Fermentation technology, antibiotic ampicillin is used as selection marker and his use showed poor plasmid stability. Instead of ampicillin, kanamycin is started to be used as selection marker. Following table lists the results of plasmid stability test obtained during flask cultivation.

**Table 16.** Plasmid stability of four different *E. coli* strains at three time points after induction.

strain	0 h	4 h	8 h
W3110 pAppA1	98 %	84 %	100 %
<i>Δlpp</i> pAppA1	100 %	100 %	100 %
<i>ΔompA ΔompC</i> pAppA1	100 %	100 %	100 %
<i>ΔfimD ΔyghH</i> pAppA1	100 %	100 %	100 %

As seen in Table 16, plasmid stability is 100 % for every bacterial strain except for strain *E. coli* W3110 pAppA1. The plasmid stability for sample of W3110 pAppA1 taken four hours after induction is lower than one for sample taken right after induction. It may be due to stress protein overproduction induced by IPTG causes to cells. In the last sampling point, plasmid stability increased to 100 %. To conclude, growth, induction, protein biosynthesis, folding, transport through inner membrane, secretion through outer membrane, cell lysis and instability of phytase substrate easily lead to significant differences in results.

## 4.2. Bioreactor cultivation

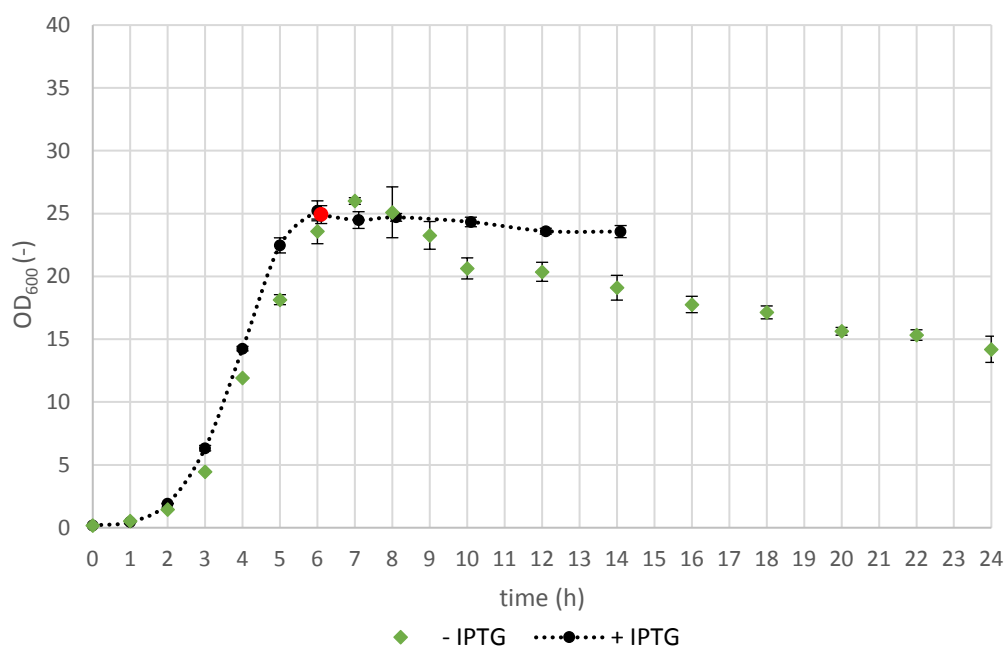
One of the aims of this thesis was to examine the secretion of proteins during fermentation of certain *E. coli* strains. Flask cultivation was performed to select the strain with the best secretion efficiency. All aspects were considered to decide which strain is going to be cultivated in a bioreactor, but results of enzyme assay were crucial. *E. coli*  $\Delta lpp$  pAppA1 has already been shown to have a good secretion ability and compared to the other tested strains, it has shown the highest enzyme activity in supernatant at eighth hour after induction. *E. coli*  $\Delta ompA \Delta ompC$  pAppA1 was constructed in Laboratory of Fermentation Technology and it showed the second-best enzyme activity in supernatant at eighth hour after induction. Also, this strain showed highest normalized activity at the same time point. Protein concentration in supernatant and cell lysate of *E. coli*  $\Delta lpp$  pAppA1 and *E. coli*  $\Delta ompA \Delta ompC$  pAppA1 was approximately the same so it was not crucial criteria for next experiments. Because of these reasons, both strains were selected to be cultivated in bioreactor.

Both strains were cultivated in TB medium. It used for large-scale cultures because obtained cell densities can be significantly higher than densities when using LB medium, which is usually used for small-scale cultures (Losen *et al.*, 2004). In a difference to flask cultivation, induction was made at the beginning of stationary phase aiming first the achievement of high OD<sub>600</sub> and then the production and secretion of AppA protein, i.e. growth-decoupled protein production. After inoculation and further growth, the inducer is often added in mid-log phase because the culture is growing fast and protein translation is maximal. However, induction at early stationary phase is also possible (Rosano and Ceccarelli, 2014). In fact, in some cases the target protein was more soluble when inducer was added at this stage (Galloway *et al.*, 2003). Two fermentations were performed per each strain. Purpose of the first fermentation was to determine the timepoint at which culture enters the stationary phase in order to do induction during second fermentation at a determined timepoint.

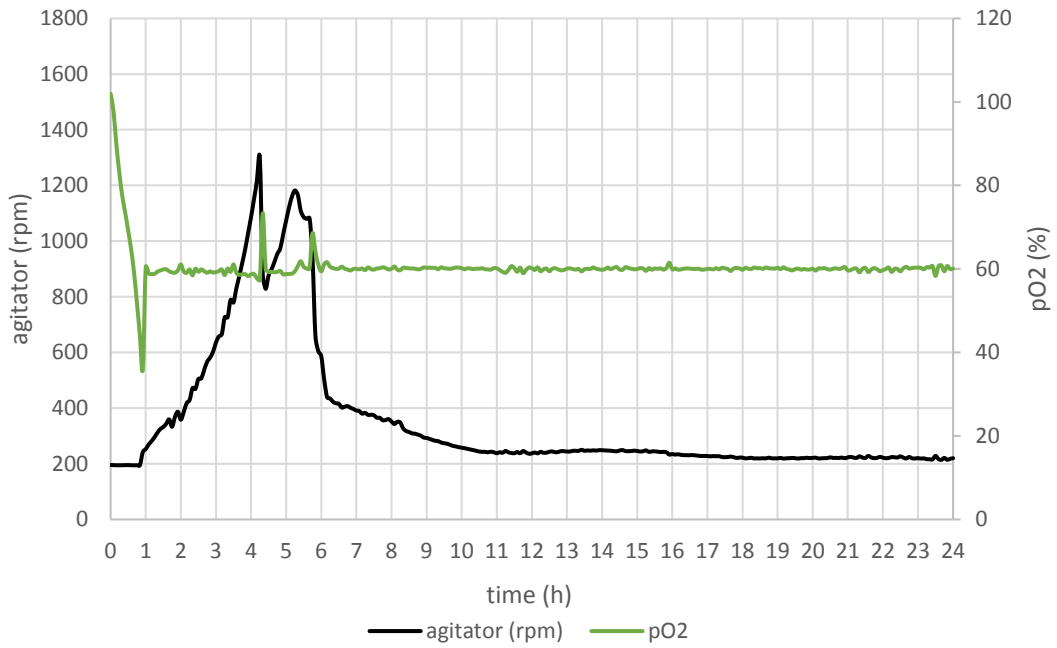


#### 4.2.1. Bioreactor cultivation of *Escherichia coli* $\Delta ompA \Delta ompC$ pAppA1

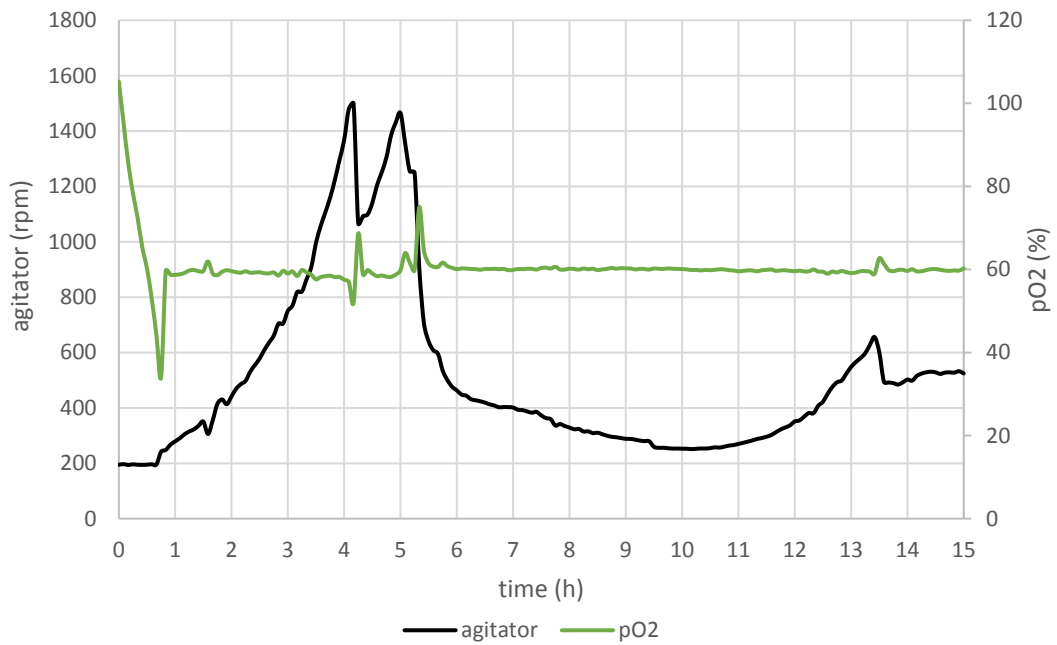
*E. coli*  $\Delta ompA \Delta ompC$  pAppA1 was cultivated in 5 L bioreactor in TB medium under conditions described before in chapter Batch cultivation. Samples for measuring enzyme activity and determining protein concentration as well as for SDS-PAGE and plasmid stability were taken 1, 2, 4, 6 and 8 hours after induction. As for flask cultivation, enzyme activity and protein concentration were determined in supernatant and in cell lysate.



**Figure 21.** Growth curve of *E. coli*  $\Delta ompA \Delta ompC$  pAppA1. The red dot stands for the moment of induction



**Figure 22.** Parameters of first cultivation of *E. coli*  $\Delta ompA \Delta ompC$  pAppA1 without induction of protein production



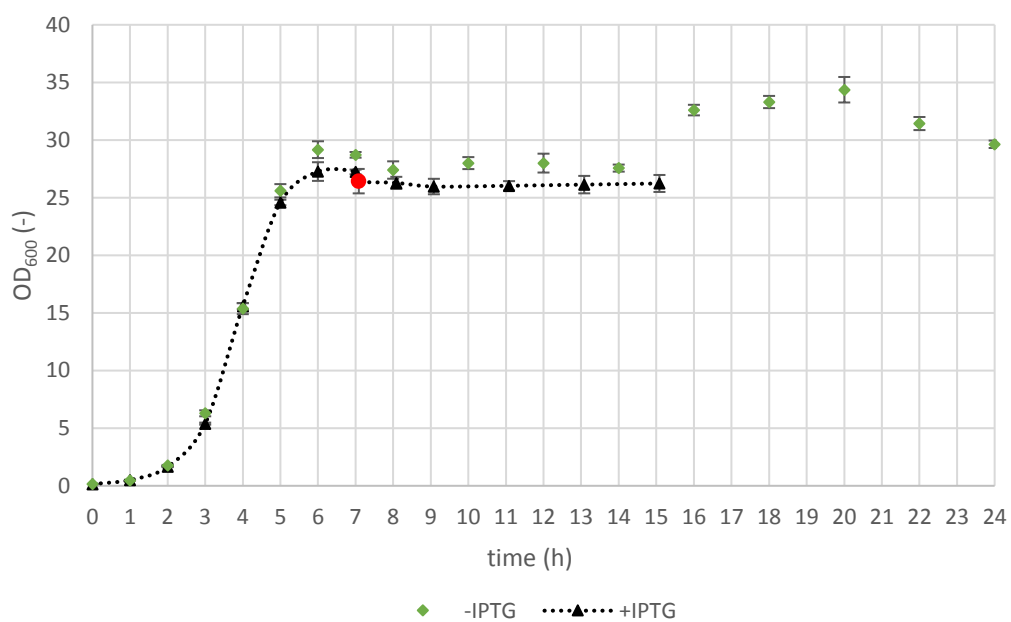
**Figure 23.** Parameters of the second cultivation of *E. coli*  $\Delta ompA \Delta ompC$  pAppA1 with induction of protein production

Figure 21 shows bacterial growth curves of strain  $\Delta ompA \Delta ompC$  pAppA1 monitored by measuring OD<sub>600</sub> value. OD<sub>600</sub> was measured for 24 hours for cultivation where inductor has not been added and for eight hours after induction when IPTG has been added. Green line stands for first fermentation in which start of stationary phase was supposed to be determined, while black line stands for second fermentation in which inductor was added. It can be noticed that stationary phase did not occur during first fermentation. After reaching maximal OD<sub>600</sub> value of  $26.00 \pm 0.26$  in seventh hour, cells immediately enter death phase. Dissolved oxygen level rapidly drops in first hours of cultivation (Figure 22) and prior to induction reaches 70 %. After induction it decreases to 60 % and remains constant until the end of the cultivation. Dissolved oxygen level was kept at 60 % of air saturation by controlling the cascading impeller speed. Stirrer speed was up to 1500 rpm when oxygen level was on the lowest point. It could cause significant shear stress to the cells that are sensitive due to weakened cell wall. It has been already been shown that OmpA stability is related to the stress survival of *E. coli* (Wang, 2002). Highest impeller rotation value was just before cells were supposed to enter stationary phase. It may be, that due to shear stress cells skipped stationary phase and entered death phase immediately during the first fermentation. Following that logic, during second cultivation cells were supposed to behave similarly, especially because of additional stress caused by IPTG. Opposite of expectations, cells normally enter stationary phase.

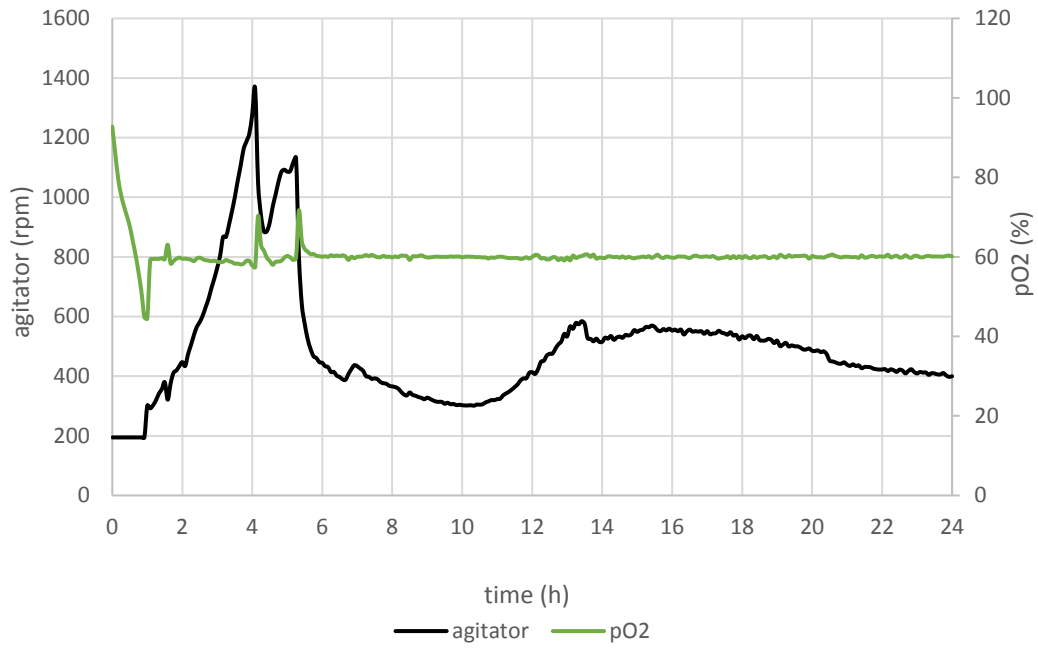
During second fermentation of  $\Delta ompA \Delta ompC$  pAppA1 strain (Figure 21 and 23), IPTG was added in sixth hour of cultivation (Figure 21, red dot), one hour before reaching maximal OD<sub>600</sub> value measured in previous cultivation. After induction, cells seem to enter stationary phase, remaining OD<sub>600</sub> value about 24. What also can be noticed is that cells during second cultivation have higher specific growth rate than cells in the first cultivation. Maximal specific growth rate  $\mu_{max}$  for first fermentation was  $0.54 \text{ h}^{-1}$ , while  $\mu_{max}$  for second fermentation was  $0.63 \text{ h}^{-1}$ . Percentage of pO<sub>2</sub> and agitator speed during the cultivations are shown in figures 22 and 23. In figures 22 and the agitator speed can be followed through two peaks around 4 and 5 h. Due to almost stable pO<sub>2</sub> one can say, that there is diauxic growth, which is no wonder using complex TB medium. That means also, that at 4h and 5h the exponential growth stopped. Other cultivation parameters, pH, temperature and overpressure, were kept constant, and therefore they are not shown in charts.

#### 4.2.2. Bioreactor cultivation of *E. coli* $\Delta lpp$ pAppA1

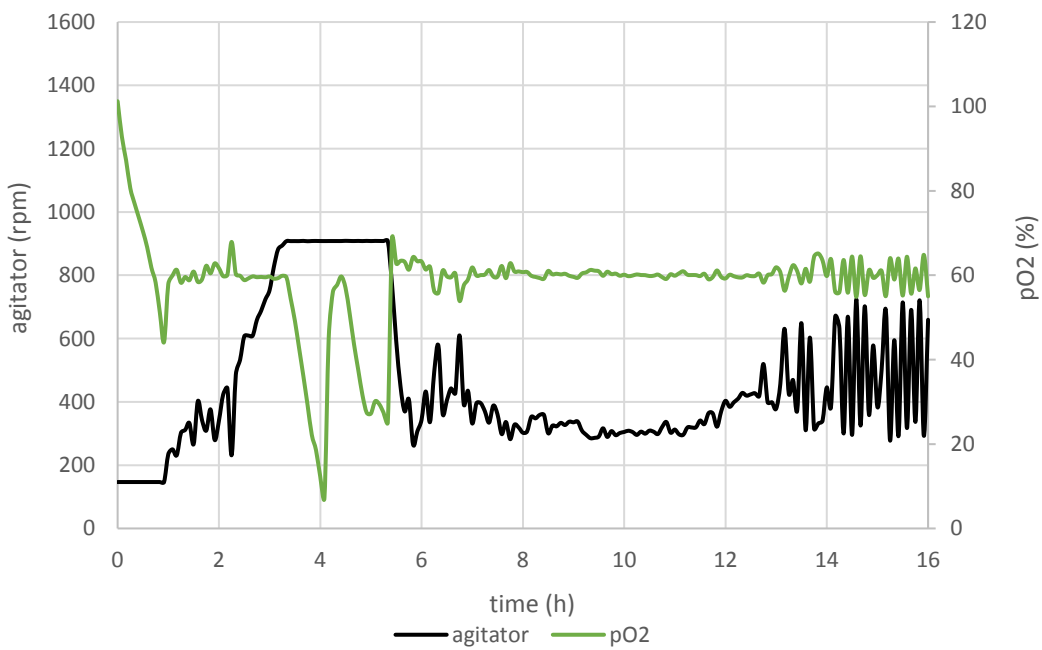
*E. coli* strain  $\Delta lpp$  pAppA1 was cultivated in 12 L of TB medium under conditions described before in chapter Batch cultivation. Samples for measuring enzyme activity and determining protein concentration as well as for SDS-PAGE and plasmid stability were taken 1, 2, 4, 6 and 8 hours after induction. As for flask cultivation, enzyme activity and protein concentration were determined in supernatant and in cell lysate.



**Figure 24.** Growth curve of *E. coli* strain  $\Delta lpp$  pAppA1. The red dot stands for the moment of induction



**Figure 25.** *E. coli*  $\Delta lpp$  pAppA1 cultivation parameters without the induction of protein production



**Figure 26.** *E. coli*  $\Delta lpp$  pAppA1 cultivation parameters with the induction of protein production

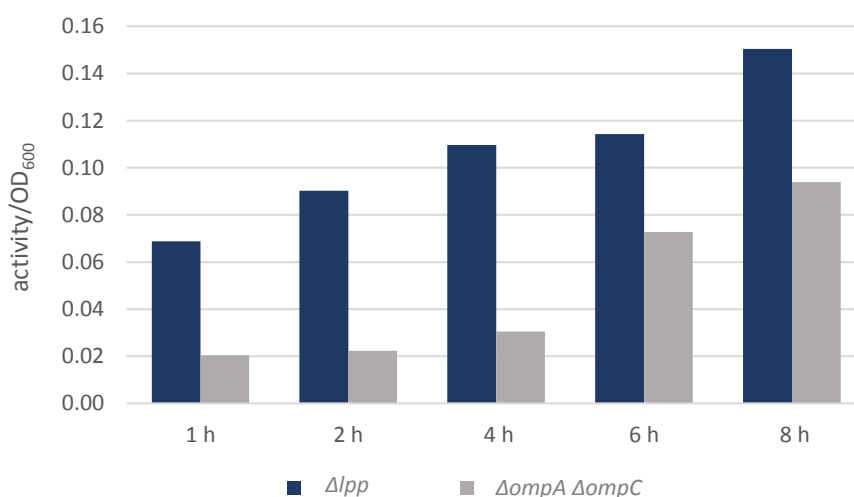
During the first fermentation (Figure 24, green marker), highest OD<sub>600</sub> value reached was 34.37±1.11 at 20. hour and it was not measured at the beginning of the stationary phase. Cells entered stationary phase after reaching OD<sub>600</sub> of 27.40±0.75 and cell density mostly remained close to that value. After 14 hours of cultivation, OD<sub>600</sub> value increases again and death phase did not occur until after the 20. hour of cultivation. As previously reported, the *Δlpp* mutant could withstand the shear stress typically encountered in a bioreactor and exhibited similar growth behaviour to shaker flask conditions where recombinant proteins were produced (Shin and Chen, 2008). Unlike *ΔompA ΔompC pAppA1* strain, two fermentations of *Δlpp* strain seem to be more alike, at least when it comes to exponential growth phase. In both cultivations, maximal specific growth rate,  $\mu_{\max}$ , was the same, 0.70 h<sup>-1</sup>. During the second fermentation, IPTG was added in sixth hour of cultivation (Figure 24, red dot), one hour before reaching maximal OD<sub>600</sub> value measured at the beginning of stationary phase determined during the first cultivation of this strain. After the induction, cells seem to enter stationary phase, remaining OD<sub>600</sub> value about 24 until the end of cultivation. Figures 25 and 26 show pO<sub>2</sub> and agitator speed during cultivations of *E. coli Δlpp* strain. During the cultivation without the induction of protein production, two peaks can be seen on agitator curve. It may be due to diauxic growth occurring in a complex medium such as TB or even because of the possible contamination.

### 4.2.3. Enzyme assay results

Table 17 show enzyme assay results and OD<sub>600</sub> results for strains cultivated in bioreactor.

**Table 17.** Enzyme assay and OD<sub>600</sub> results obtained during bioreactor cultivation

strain	time after induction (h)	OD <sub>600</sub>	total enzyme activity (U mL <sup>-1</sup> )		normalized enzyme activity (U mL <sup>-1</sup> )	
			Supernatant	cell lysate	supernatant	cell lysate
<i>ΔompA</i> <i>ΔompC</i> pAppA1	1	24,48 ± 0,67	0,50 ± 0,01	20,06 ± 0,53	0,02	0,82
	2	24,70 ± 0,30	0,55 ± 0,00	17,56 ± 1,60	0,02	0,71
	4	24,33 ± 0,38	0,74 ± 0,02	13,35 ± 0,61	0,03	0,55
	6	23,60 ± 0,23	1,72 ± 0,06	20,96 ± 0,44	0,07	0,89
	8	23,57 ± 0,48	2,21 ± 0,11	22,49 ± 1,10	0,09	0,95
<i>Δlpp</i> pAppA1	1	26,28 ± 0,53	1,81 ± 0,08	10,48 ± 0,21	0,07	0,40
	2	25,97 ± 0,67	2,34 ± 0,08	10,18 ± 0,52	0,09	0,39
	4	26,03 ± 0,40	2,86 ± 0,08	12,01 ± 0,49	0,11	0,46
	6	26,13 ± 0,76	2,99 ± 0,22	17,54 ± 0,47	0,11	0,67
	8	26,23 ± 0,74	3,94 ± 0,13	22,17 ± 3,35	0,15	0,85



**Figure 27.** Normalized phytase activity in supernatants of *E. coli* strains *ΔompA ΔompC* pAppA1 and *Δlpp* pAppA1 cultivated in bioreactor. Time points are for the time after induction.

In supernatant of strain  $\Delta ompA \Delta ompC$  pAppA1, phytase activity increases over time and reaches maximal value  $2,21 \pm 0,11 \text{ U mL}^{-1}$  eight hours after induction while phytase activity in cell lysate decreases and reaches lowest value in fourth hour after induction. Then, activity increases again and reaches maximal value eight hours after induction (Table 17) One of the reasons could be lowered plasmid stability, but results of plasmid stability test do not support this assumption because plasmid stability remains 100 % over the whole time of cultivation. It is hard to compare results of enzyme assay obtained during flask cultivation to those obtained during bioreactor cultivation due to different time of induction. In bioreactor cultivation, induction was done at the beginning of the stationary phase when cell density was already higher than one measured at the end of flask cultivation. As for flask cultivation, this strain showed good protein production ability what can be concluded from high values of enzyme activity of cell lysate. When recombinant proteins are expressed in the periplasm, accumulation of the proteins in the periplasmic space often adversely affects the growth of the cell (Sugamata and Shiba, 2005). It may be the reason why cell density of  $\Delta ompA \Delta ompC$  pAppA1 is slowly decreasing over time after induction.

Enzyme activity in supernatant of strain  $\Delta lpp$  pAppA1 increases over time and reaches maximal value of  $3.94 \text{ U mL}^{-1}$ , eight hours after induction. It reaches value more than double higher than in the first hour of induction, suggesting prolonged time of cultivation increases excreted protein concentration in nutrient medium. In cell lysate, phytase activity increases as well and reaches maximal value  $22,17 \pm 3.35 \text{ U mL}^{-1}$  also in eighth hour after induction. Compared to the activity in supernatant of strain  $\Delta ompA \Delta ompC$  pAppA1, total activity in supernatant of strain  $\Delta lpp$  pAppA1 is 4,3 x higher in the second hour after induction. If  $OD_{600}$  is also included as an important factor of characterization of protein secretion, normalized activity results show that  $\Delta lpp$  pAppA1 remains better secreting strain and strain  $\Delta ompA \Delta ompC$  pAppA1 remains better producing strain (Figure 27) because  $\Delta lpp$  pAppA1 reaches up to 4,5 x higher normalized activity in supernatant pAppA1 and twice as lower normalized activity in cell lysate than the  $\Delta ompA \Delta ompC$  pAppA1.

In paper by Miksch *et al.* it was reported that secretion of phytase increased until a cultivation time of 35 h, resulting in most of the phytase produced being found in the medium. They also showed that total expression of phytase was significantly increased when the strain was able to release phytase into the medium (Miksch *et al.*, 2002). Considering that, prolonged time of cultivation of two cultivated strains,  $\Delta lpp$  pAppA1 and  $\Delta ompA \Delta ompC$  pAppA1, could make a difference in secretion potential and protein production ability clearer than cultivating for only



eight hours after induction point. Phytase activity achieved using batch cultivation is significantly lower than one achieved when using fed-batch cultivation (Kleist *et al.*, 2003). There were other examples of high phytase activity results (Xiong *et al.*, 2005; Vohra and Satyanarayana, 2003) and *E. coli* phytase had one of the highest specific activities of all organisms tested so far. It was eight times higher than of the commercially used *Aspergillus niger* phytase (Miksch *et al.*, 2002). Additionally, in contrast to the fungal phytase enzyme, *E. coli* phytase was found to be both highly resistant to proteolytic degradation in the stomach of monogastric animals, and more resistant to high temperatures during the pelleting process. Therefore, it would be highly desirable to produce the phytase of *E. coli* for practical applications (Kleist *et al.*, 2003).

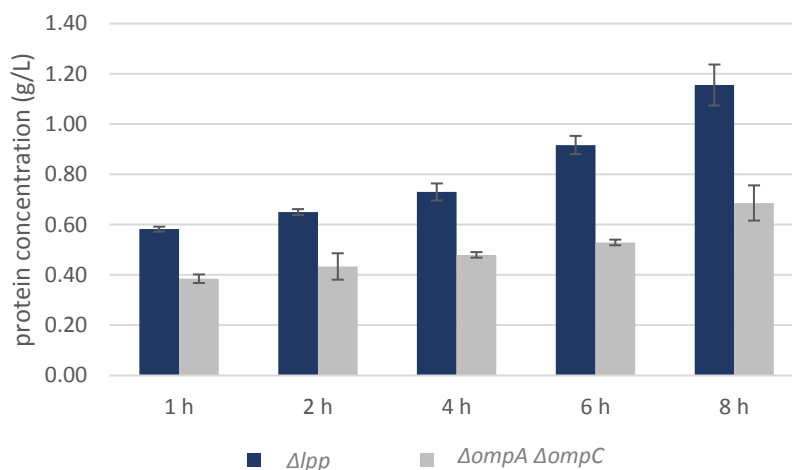
**Table 18.** Percentage of activity in supernatant.

	<b>1 h</b>	<b>2 h</b>	<b>4 h</b>	<b>6 h</b>	<b>8 h</b>
<i>Δlpp</i> pAppA1	17.24 %	23.02 %	23.77 %	17.02 %	17.79 %
<i>ΔompA ΔompC</i> pAppA1	2.48 %	3.13 %	5.56 %	8.19 %	9.84 %

Percentage of activity (Table 18) in supernatant of *E. coli* culture, strain *Δlpp* pAppA1, increases and reaches maximum at fourth hour after induction. Although enzyme activity in supernatant of strain *Δlpp* pAppA1 is increasing in each hour after induction, share of activity in supernatant increases only until fourth hour after induction and then decreases. Possible reason could be that, over time, phytase expression is getting higher than its secretion and cannot be released to the medium due to limitations of bacterial secretion system. Also, it might happen due to overheating the sample during the sonication. Percentage of activity in supernatant of strain *ΔompA ΔompC* pAppA1 is increasing as well as total activity in supernatant. However, percentage of activity in supernatant of *ΔompA ΔompC* pAppA1 is lower than 10 % at eighth hour after induction which is far behind from the values calculated for the sample taken one hour after the induction of strain *Δlpp* pAppA1. Once again, results listed in this table support results of enzyme and protein concentration assays (Figure 28).

#### 4.2.4. Protein concentration assay

Following figure shows comparison of protein concentration measured in supernatants of cultivated strains. Time points refer to the time after induction point. Results of protein concentration in cell lysate are not shown.

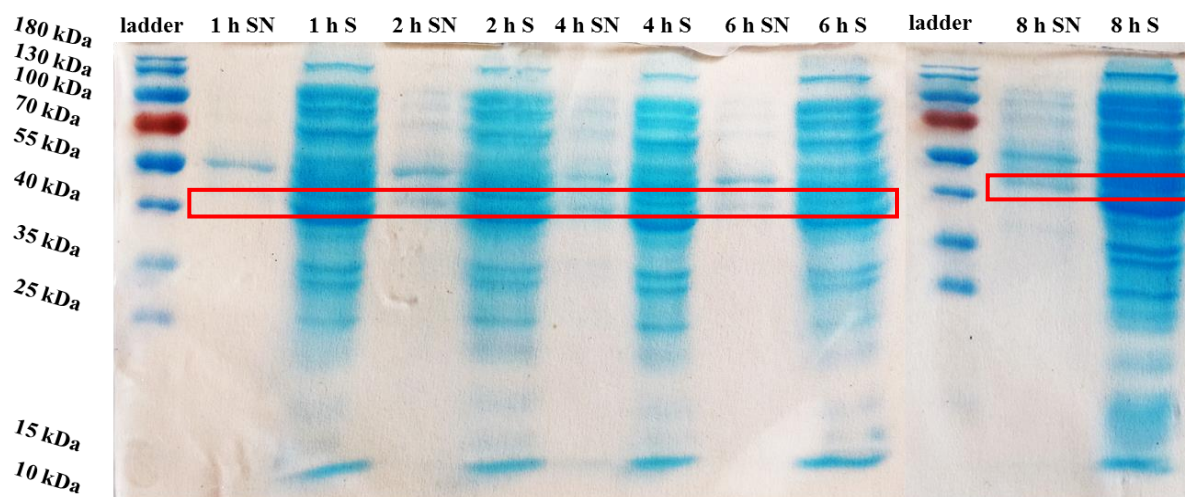


**Figure 28.** Protein concentration in supernatant of *E. coli*  $\Delta lpp$  and *E. coli*  $\Delta ompA \Delta ompC$  *pAppA1*.

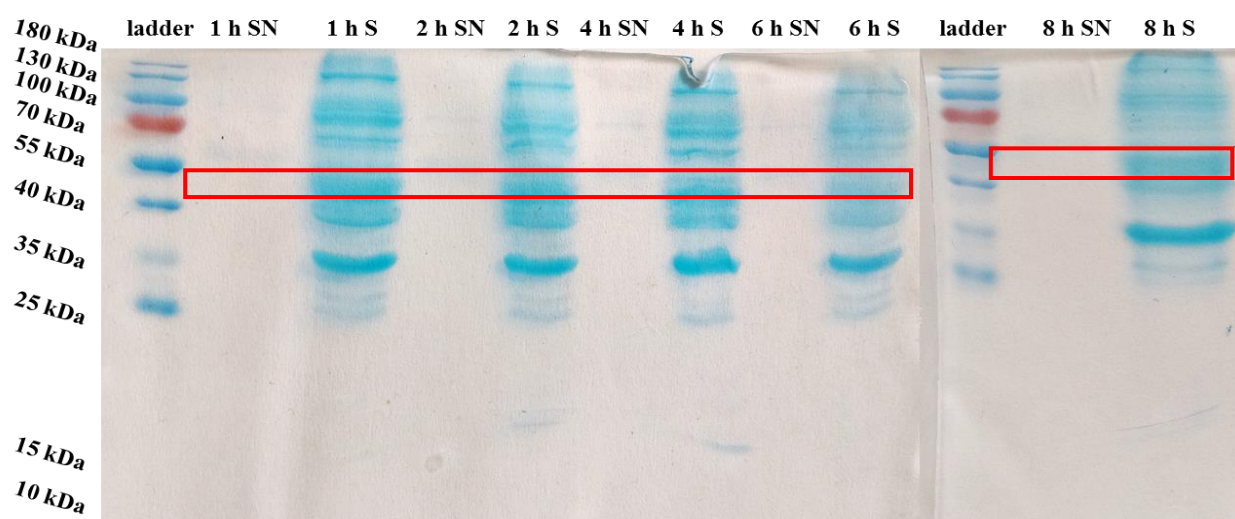
For both strains, protein concentration in supernatant increases over time what matches the results of enzyme activity test and  $OD_{600}$  (Table 17). Protein concentration in supernatant of strain  $\Delta ompA \Delta ompC$  *pAppA1* reaches maximal value of  $0.69 \pm 0.07$  g/L eight hours after induction and it is almost twice as high as in the first hour after induction. Total protein concentration detected in supernatant of strain  $\Delta lpp$  *pAppA1* is in general higher than one detected in supernatant samples of strain  $\Delta ompA \Delta ompC$  *pAppA1*. It also fits the results of enzyme assay, but it is not confirmed on SDS-PAGE gel presented in the following chapter.

#### 4.2.5. SDS – PAGE

Figures 29 and 30 show protein bands on SDS-PAGE gels of samples taken during batch cultivation of two tested strains,  $\Delta lpp$  pAppA1 and  $\Delta ompA \Delta ompC$  pAppA1 with induced protein production.



**Figure 29.** SDS – PAGE, *E. coli*  $\Delta ompA \Delta ompC$  pAppA1. 1h, 2h, 4h, 6h and 8h stand for time after induction samples were taken at. SN stands for supernatant and S stands for cell lysate and supernatant sample together. Red box shows phytase band.



**Figure 30.** SDS – PAGE, *E. coli*  $\Delta lpp$  pAppA1. 1h, 2h, 4h, 6h and 8h stand for time after induction samples were taken at. SN stands for supernatant and S stands for cell lysate and supernatant sample together. Red box shows phytase band.

The gels of the strain *ΔompA ΔompC pAppA1* show in the supernatant samples (Figure 28, SN) that the phytase bands become stronger over the time of cultivation. First hour after induction there is no phytase band in the supernatant and it gets visible in second and third supernatant sample. It matches the enzyme assay results where activity in supernatant is increasing as well as total protein concentration in supernatant samples (Figure 29, Table 17). In supernatant sample taken at eighth hour, it can be noticed that significant contamination occurred. Also, there is slight smear in the same line at the area of proteins smaller than phytase what can possibly indicate other periplasmic proteins. For samples of protein in cell lysate of strain *ΔompA ΔompC pAppA1*, it is hard to say whether phytase band is more visible or not due to numerous proteins stained in the gel. All bands are most intensive in sample taken eight hour after induction. Opposite of SDS-PAGE made for flask cultivation of *Δlpp* strain, in gel for bioreactor cultivation of *Δlpp pAppA1* phytase bands are not so easy to see in supernatant samples (Figure 30). There is no visible phytase protein band in supernatant sample taken one hour after induction as well as in one taken eight hours after induction. It does not match nor enzyme activity test or protein concentration in respective sample. This result can be a consequence of error that occurred during sample preparation. Absence or poor visibility of other bands could support this assumption. As well as for supernatant samples, cell lysate samples of strain *Δlpp pAppA1* are less visible for bioreactor cultivation than for flask cultivation of the same strain. SDS-PAGE results support previous assumption that strain *ΔompA ΔompC pAppA1* is better producer of proteins than *Δlpp pAppA1* strain what is seen the best when looking at lane that corresponds to cell lysate samples taken in eighth hour after induction.

## 5. CONCLUSION AND OUTLOOK

Within the scope of this thesis, one single and two double knock-out mutants of *Escherichia coli* were characterized. Strain W3110 was used as a reference strain as it is considered as wild-type. Single knock-out deletion mutant,  $\Delta lpp$ , has already been proven to have a good secretion ability in patent of Wacker AG (Dassler *et al.*, 2008). Two other double knock out strains,  $\Delta ompA \Delta ompC$  pAppA1 and  $\Delta fimD \Delta yghH$  pAppA1, were constructed in Laboratory of Fermentation technology and were hoped to have increased secretion ability. Firstly, flask cultivation was carried out to have an overview of features of every strain, regarding growth, protein production and secretion. Phytase AppA was used as a reporter protein. In a second step, strains that showed the best secretion and production ability were chosen to be cultivated in bioreactors over a period of 8 after induction. Again, cultivated strains were characterized according to their secretion ability, growth and protein production.

During the flask cultivation, strains  $\Delta lpp$  pAppA1,  $\Delta ompA \Delta ompC$  pAppA1,  $\Delta fimD \Delta yghH$  pAppA1 and W3110 pAppA1 were cultivated. Highest cell density was reached during cultivation of strain,  $\Delta fimD \Delta yghH$  pAppA1 ( $28.63 \pm 0.83$ ), followed by 1.2 x lower cell density of  $\Delta ompA \Delta ompC$  pAppA1 and  $\Delta lpp$  pAppA1. Lowest cell density was one of wild type strain W3110 pAppA1 ( $7.33 \pm 0.22$ ), but activity in supernatant was more than 45 % after eight hours of cultivation from the point of induction, probably due to low totally produced protein amount. According to definition set by Dassler *et al.* (2008), only  $\Delta lpp$  pAppA1 strain that has been tested can be considered as leaky because it showed higher percentage of activity in supernatant than strain W3110. On the other hand, SDS-PAGE of the  $\Delta lpp$  pAppA1 indicated possible contamination or even cell lysis, so it would be interesting to investigate up to which protein size the different deletion mutants can release proteins from the periplasm into the medium. Considering probable mistakes in enzyme assay and unevenness of sonication procedure, not only  $\Delta lpp$  pAppA1 strain was chosen for bioreactor cultivation, but also strain  $\Delta ompA \Delta ompC$  pAppA1. Highest value of enzyme activity in cell lysate was reached for this strain ( $51.30 \pm 13.15 \text{ U mL}^{-1}$ ) and the second highest total activity in supernatant ( $1.28 \pm 0.08 \text{ U mL}^{-1}$ ). Also, protein concentration in supernatant and cell lysate samples of this strain were close to the values measured for  $\Delta lpp$  strain, that has already have been characterized as strain with good secretion ability.

In a difference to flask cultivation, induction during bioreactor cultivations was done at the very beginning of stationary phase when high cell densities were already achieved. Strain  $\Delta lpp$

pAppA1 and  $\Delta ompA \Delta ompC$  pAppA1 reached similar OD<sub>600</sub> at the point of cultivation (26). Further assessment showed that strain  $\Delta ompA \Delta ompC$  pAppA1 is more sensitive to shear stress in bioreactor than  $\Delta lpp$  pAppA1 strain, probably due to weakened cell wall structure caused by deletions of genes encoding outer membrane proteins. Enzyme activity test as well as protein concentration test confirmed previously described results in literature that  $\Delta lpp$  remains the strain with the best secretion ability so far. For the extracellular production of the phytase from *E. coli*, therefore, not all strains considered are suitable.

For further research, it would be necessary to optimize cell disruption process and quantify it. Possible way could be to dilute samples to the same OD<sub>600</sub> and then perform the same number of sonication cycles. It would, hopefully, decrease an error that occurs due to uneven disruption. Enzyme activities in the supernatant samples seem to increase over the time, so it would be interesting to prolongate the time of cultivation after induction and decrease the cell lysis. Also, optimization of batch process is necessary, including testing different nutrient media, induction time optimization and different homogenization strategies, since *leaky* mutants might seem to be sensitive to the shear stress possibly caused by vigorous stirring. Fed-batch process would enable to reach higher cell densities possibly meaning higher enzyme concentrations would be secreted into the medium. Other reporter proteins could also be used to characterize the secretion ability of a certain strain.

## 6. BIBLIOGRAPHY

- Angkawidjaja, C., Kuwahara, K., Omori, K., Koga, Y., Takano, K. and Kanaya, S. (2006) Extracellular secretion of *Escherichia coli* alkaline phosphatase with a C-terminal tag by type I secretion system: purification and biochemical characterization. *Protein Eng Des Sel*, **19** (7), 337–343.
- Anonymous 1 (2017) KEGG T00068: JW5780, <<http://www.genome.jp/dbgetbin/wwwbget?ecj:JW5780>>. Page visited October 5, 2017.
- Anonymous 2 (2017) Para-Nitrophenyl phosphate, <<https://alchetron.com/Para-Nitrophenylphosphate-4003911-W>>. Page visited October 16, 2017.
- Baba, T., Ara, T., Hasegawa, M., Takai, Y., Okumura, Y., Baba, M., Datsenko, K.A., Tomita, M., Wanner, B.L. and Mori, H. (2006) Construction of *Escherichia coli* K-12 in-frame, single-gene knockout mutants: the Keio collection. *Mol Syst Biol*, **2**, 2006.0008. doi:10.1038/msb4100050
- Baneyx, F. and Mujacic, M. (2004) Recombinant protein folding and misfolding in *Escherichia coli*. *Nat Biotech*, **22** (11), 1399–1408.
- Baslé, A., Rummel, G., Storici, P., Rosenbusch, J.P. and Schirmer, T. (2006) Crystal structure of osmoporin OmpC from *E. coli* at 2.0 Å. *J Mol Biol*, **362** (5), 933–942.
- Benson, S.A. and Decloux, A. (1985) Isolation and characterization of outer membrane permeability mutants in *Escherichia coli* K-12. *J Bacteriol*, **161** (1), 361–367.
- Beveridge, T.J. (1999) Structures of Gram-Negative Cell Walls and Their Derived Membrane Vesicles. *J Bacteriol*, **181** (16), 4725–4733.
- Braun, V. (1975) Covalent lipoprotein from the outer membrane of *Escherichia coli*. *Biochim Biophys Acta*, **415** (3), 335–377.
- Cascales, E., Bernadac, A., Gavioli, M., Lazzaroni, J.-C. and Lloubes, R. (2002) Pal Lipoprotein of *Escherichia coli* Plays a Major Role in Outer Membrane Integrity. *J Bacteriol*, **184** (3), 754–759.
- Chen, Y., Zhu, Z., Lin, X.A., Yi, Y., Zhang, Zhifang and Shen, G. (2005) Overexpression and Characterization of appA Phytase Expressed by Recombinant Baculovirus-Infected Silkworm. *J Microbiol Biotech*, **15**, 466-471.
- Chen, Z.-Y., Cao, J., Xie, L., Li, X.-F., Yu, Z.-H. and Tong, W.-Y. (2014) Construction of leaky strains and extracellular production of exogenous proteins in recombinant *Escherichia coli*. *Microb Biotechnol*, **7** (4), 360–370.
- Choi, J.H. and Lee, S.Y. (2004) Secretory and extracellular production of recombinant proteins using *Escherichia coli*. *Appl Microbiol Biot*, **64** (5), 625–635.
- Costa, T.R.D., Felisberto-Rodrigues, C., Meir, A., Prevost, M.S., Redzej, A., Trokter, M. and Waksman, G. (2015) Secretion systems in Gram-negative bacteria: structural and mechanistic insights. *Nat Rev Microbiol*, **13** (6), 343–359.

- Cowan, S.W., Schirmer, T., Rummel, G., Steiert, M., Ghosh, R., Pauptit, R.A., Jansonius, J.N. and Rosenbusch, J.P. (1992) Crystal structures explain functional properties of two *E. coli* porins. *Nature*, **368** (6389), 727–733.
- Cristóbal, S., Gier, J.W. de, Nielsen, H. and Heijne, G. von (1999) Competition between Sec- and TAT-dependent protein translocation in *Escherichia coli*. *EMBO J*, **18** (11), 2982–2990.
- Cserjan-Puschmann, M., Grabherr, R., Striedner, G., Clememtschitsch, F. and Bayer, K. (2002) Optimizing recombinant microbial fermentation processes. An integrated approach. *Biopharm*, **15** (7), 26–34.
- Dassa, E. and Boquet, P.L. (1985) Identification of the gene *appA* for the acid phosphatase (pH optimum 2.5) of *Escherichia coli*. *Mol Gen Genet*, **200** (1), 68–73.
- Dassa, E., Cahu, M., Desjoyaux-Cherel, B. and Boquet, P.L. (1982) The acid phosphatase with optimum pH of 2.5 of *Escherichia coli*. Physiological and Biochemical study. *J Biol Chem*, **257** (12), 6669–6676.
- Dassa, E., Tetu, C. and Boquet, P. L. (1980) Identification of the acid phosphatase (optimum pH 2.5) of *Escherichia coli*. *FEBS Lett*, **113**, 68-73.
- Dassler, T., Guenter, W. and Schmid, G. (2008) Process for the fermentative production of proteins. No. US20080254511 A1.
- Delepelaire, P. (2004) Type I secretion in gram-negative bacteria. *Biochim Biophys Acta*, **1694** (1-3), 149–161.
- Driessen, A. (2001) SecB, a molecular chaperone with two faces. *Trends Microbiol*, **9** (5), 193–196.
- Dvorak, P., Chrast, L., Nikel, P., Fedr, R., Soucek, K., Sedlackova, M., Chaloupkova, R., de Lorenzo, V., Prokop, Z. and Damborsky, J. (2015) Exacerbation of substrate toxicity by IPTG in *Escherichia coli* BL21(DE3) carrying a synthetic metabolic pathway. *Microb Cell Fact*, **14** (1), 201-216.
- Elias, C.B., Zeiser, A., Bédard, C. and Kamen, A.A. (2000) Enhanced growth of sf-9 cells to a maximum density of  $5.2 \times 10^7$  cells per mL and production of  $\beta$ -galactosidase at high cell density by fed batch culture. *Biotechnol Bioeng*, **68** (4), 381–388.
- Fahnert, B., Lilie, H. and Neubauer, P. (2004) Inclusion Bodies. Formation and Utilisation. *Biochem Engin/Biotechnol*, **89**, 93–142.
- Fernandez, L.A. (2004) Prokaryotic expression of antibodies and affibodies. *Curr Opin Biotech*, **15** (4), 364–373.
- Galloway, C.A., Sowden, M.P. and Smith, H.C. (2003) Increasing the yield of soluble recombinant protein expressed in *E. coli* by induction during late log phase. *BioTechniques*, **34** (3), 524-526, 528, 530.
- Gentschev, I., Dietrich, G. and Goebel, W. (2002) The *E. coli* alpha-hemolysin secretion system and its use in vaccine development. *Trend Microbiol*, **10** (1), 39–45.
- Gohlke, U., Pullan, L., McDevitt, C.A., Porcelli, I., Leeuw, E. de, Palmer, T., Saibil, H.R. and Berks, B.C. (2005) The TatA component of the twin-arginine protein transport system



forms channel complexes of variable diameter. *P Natl Acad Sci USA*, **102** (30), 10482–10486.

Green, E.R. and Meccas, J. (2016) Bacterial Secretion Systems: An Overview. *Microbiol Spect*, **4** (1), doi: 10.1128/microbiolspec.VMBF-0012-2015.

Greiner, R. (2017) Activity of *Escherichia coli*, *Aspergillus niger* and Rye Phytase towards Partially Phosphorylated myo-Inositol Phosphates. *J Agr Food Chem*, doi: 10.1021/acs.jafc.7b03897.

Greiner, R., Konietzny, U. and Jany, K.D. (1993) Purification and characterization of two phytases from *Escherichia coli*. *Arch Biochem Biophys*, **303** (1), 107–113.

Gumbart, J.C., Beeby, M., Jensen, G.J. and Roux, B. (2014) *Escherichia coli* peptidoglycan structure and mechanics as predicted by atomic-scale simulations. *PLoS Comput Biol*, **10** (2), e1003475.

Gumpert, J. and Hoischen, C. (1998) Use of cell wall-less bacteria (L-forms) for efficient expression and secretion of heterologous gene products. *Curr Opin Biotech*, **9** (5), 506–509.

Hayashi, K., Morooka, N., Yamamoto, Y., Fujita, K., Isono, K., Choi, S., Ohtsubo, E., Baba, T., Wanner, B.L., Mori, H. and Horiuchi, T. (2006) Highly accurate genome sequences of *Escherichia coli* K-12 strains MG1655 and W3110. *Mol Syst Biol*, **2**, 2006.0007. doi: 10.1038/msb4100049

Hoischen, C., Fritsche, C., Gumpert, J., Westermann, M., Gura, K. and Fahnert, B. (2002) Novel bacterial membrane surface display system using cell wall-less L-forms of *Proteus mirabilis* and *Escherichia coli*. *Appl Environ Microb*, **68** (2), 525–531.

Jalalirad, R. (2013) Selective and efficient extraction of recombinant proteins from the periplasm of *Escherichia coli* using low concentrations of chemicals. *J Ind Microbio Biot*, **40** (10), 1117–1129.

Jensen, K.F. (1993) The *Escherichia coli* K-12 "wild types" W3110 and MG1655 have an rph frameshift mutation that leads to pyrimidine starvation due to low pyrE expression levels. *J Bacteriol*, **175** (11), 3401–3407.

Jeong, K.J. and Lee, S.Y. (2002) Excretion of Human  $\beta$ -Endorphin into Culture Medium by Using Outer Membrane Protein F as a Fusion Partner in Recombinant *Escherichia coli*. *Appl Environ Microb*, **68** (10), 4979–4985.

Journet, L. and Cascales, E. (2016) The Type VI Secretion System in *Escherichia coli* and Related Species. *EcoSal Plus*, **7** (1), doi: 10.1128/ecosalplus.ESP-0009-2015.

Kane, J.F. and Hartley, D.L. (1988) Formation of recombinant protein inclusion bodies in *Escherichia coli*. *Trends Biotechnol*, **6** (5), 95–101.

Keyzer, J. de, van der Does, C. and Driessen, A.J.M. (2003) The bacterial translocase: a dynamic protein channel complex. *Cell Mol Life Sci*, **60** (10), 2034–2052.

Kleist, S., 2002. Optimierung eines fermentativen Verfahrens zur Herstellung einer bakteriellen Phytase, Bielefeld (Germany): Bielefeld University.

- Kleist, S., Miksch, G., Hitzmann, B., Arndt, M., Friehs, K. and Flaschel, E. (2003) Optimization of the extracellular production of a bacterial phytase with *Escherichia coli* by using different fed-batch fermentation strategies. *Appl Microbiol Biot*, **61** (2-6), 456–462.
- Kleman, G.L. and Strohl, W.R. (1994) Acetate metabolism by *Escherichia coli* in high-cell-density fermentation. *Appl Env Microbiol*, **60** (11), 3952–3958.
- Koebnik, R., Locher, K.P. and van Gelder, P. (2000) Structure and function of bacterial outer membrane proteins: barrels in a nutshell. *Mol Microbiol*, **37** (2), 239–253.
- Lee, P.A., Tullman-Ercek, D. and Georgiou, G. (2006) The bacterial twin-arginine translocation pathway. *Ann Rev Microbiol*, **60**, 373–395.
- Lee, S.Y. (1996) High cell-density culture of *Escherichia coli*. *Trends Biotechnol*, **14** (3), 98–105.
- Lei, X.G. and Porres, J.M. (2003) Phytase enzymology, applications, and biotechnology. *Biotechnol Lett*, **25** (21), 1787–1794.
- Li, G., Yang, S., Li, M., Qiao, Y. and Wang, J. (2009) Functional analysis of an *Aspergillus ficuum* phytase gene in *Saccharomyces cerevisiae* and its root-specific, secretory expression in transgenic soybean plants. *Biotechnol Lett*, **31** (8), 1297–1303.
- Li, Y., Chen, C.X., Specht, B.-U. von and Hahn, H.P. (2002) Cloning and hemolysin-mediated secretory expression of a codon-optimized synthetic human interleukin-6 gene in *Escherichia coli*. *Protein Expres Purif*, **25** (3), 437–447.
- Liu, Y.-F., Yan, J.-J., Lei, H.-Y., Teng, C.-H., Wang, M.-C., Tseng, C.-C. and Wu, J.-J. (2012) Loss of Outer Membrane Protein C in *Escherichia coli* Contributes to Both Antibiotic Resistance and Escaping Antibody-Dependent Bactericidal Activity. *Infect Immun*, **80** (5), 1815–1822.
- Long, C.P. and Antoniewicz, M.R. (2014) Metabolic flux analysis of *Escherichia coli* knockouts: lessons from the Keio collection and future outlook. *Curr Opin Biotech*, **28**, 127–133.
- Losen, M., Frölich, B., Pohl, M. and Büchs, J. (2004) Effect of oxygen limitation and medium composition on *Escherichia coli* fermentation in shake-flask cultures. *Biotechnol Progr*, **20** (4), 1062–1068.
- Luirink, J., Heijne, G. von, Houben, E. and Gier, J.-W. de (2005) Biogenesis of inner membrane proteins in *Escherichia coli*. *Ann Review Microbiol*, **59**, pp. 329–355.
- Mergulhão, F.J.M., Summers, D.K. and Monteiro, G.A. (2005) Recombinant protein secretion in *Escherichia coli*. *Biotechnol Adv*, **23** (3), 177–202.
- Miksch, G., Flaschel, E., Breves, R., Maurer, K.-H. and Kleist, S. (2004) Method for producing recombinant proteins by gram-negative bacteria No. US20040005695A1.
- Miksch, G., Kleist, S., Friehs, K. and Flaschel, E. (2002) Overexpression of the phytase from *Escherichia coli* and its extracellular production in bioreactors. *Appl Microbiol Biot*, **59** (6), 685–694.

- Miksch, G., Ryu, S., Risse, J.M. and Flaschel, E. (2008) Factors that influence the extracellular expression of streptavidin in *Escherichia coli* using a bacteriocin release protein. *Appl Microbiol Biot*, **81** (2), 319–326.
- Misra, R. and Benson, S.A. (1988) Isolation and characterization of OmpC porin mutants with altered pore properties. *J Bacteriol*, **170** (2), 528–533.
- Müller, J.M., Wetzel, D., Flaschel, E., Friehs, K. and Risse, J.M. (2016) Constitutive production and efficient secretion of soluble full-length streptavidin by an *Escherichia coli* 'leaky mutant'. *J Biotechnol*, **221**, 91-100.
- Naglak, T.J. and Wang, H.Y. (1990) Recovery of a foreign protein from the periplasm of *Escherichia coli* by chemical permeabilization. *Enzyme Microb Tech*, **12** (8), 603–611.
- Natale, P., Brüser, T. and Driessen, A.J.M. (2008) Sec- and Tat-mediated protein secretion across the bacterial cytoplasmic membrane--distinct translocases and mechanisms. *Biochim Biophys Acta*, **1778** (9), 1735–1756.
- Neidhardt, F.C., Ingraham, J.L. and Schaechter, M. (op. 1990), Physiology of the bacterial cell: A molecular approach. Doi: 10.1016/0307-4412(92)90139-D.
- Ni, Y. and Chen, R. (2009) Extracellular recombinant protein production from *Escherichia coli*. *Biotechnol Lett*, **31** (11), 1661.
- Ni, Y., Reye, J. and Chen, R.R. (2007) *lpp* deletion as a permeabilization method. *Biotechnol Bioeng*, **97** (6), 1347–1356.
- Oh, B.-C., Choi, W.-C., Park, S., Kim, Y.-o. and Oh, T.-K. (2004) Biochemical properties and substrate specificities of alkaline and histidine acid phytases. *Appl Microbiol Biot*, **63** (4), 362–372.
- Ostanin, K., Harms, E.H., Stevis, P.E., Kuciel, R., Zhou, M.M. and van Etten, R.L. (1992) Overexpression, site-directed mutagenesis, and mechanism of *Escherichia coli* acid phosphatase. *J Biol Chem*, **267** (32), 22830–22836.
- Ou, J., Wang, L., Ding, X., Du, J., Zhang, Y., Chen, H. and Xu, A. (2004) Stationary phase protein overproduction is a fundamental capability of *Escherichia coli*. *Biochem Bioph Res Co*, **314** (1), 174–180.
- PDBe (2000) – Protein Data Bank in Europe, < <http://www.ebi.ac.uk/pdbe/entry/pdb/1dkp/>>. Page visited September 10, 2017.
- Randall, L., Topping, T. and Hardy, S. (1990) No specific recognition of leader peptide by SecB, a chaperone involved in protein export. *Science*, **248** (4957), 860–863.
- Reddy, N.R., Sathe, S.K. and Salunkhe, D.K. (1982) Phytates in legumes and cereals. *Adv Food Res*, **28**, 1–92.
- Rêgo, A.T., Chandran, V. and Waksman, G. (2010) Two-step and one-step secretion mechanisms in Gram-negative bacteria: contrasting the type IV secretion system and the chaperone-usher pathway of pilus biogenesis. *Biochem J*, **425** (3), 475–488.

- Robinson, C., Matos, C.F.R.O., Beck, D., Ren, C., Lawrence, J., Vasisht, N. and Mendel, S. (2011) Transport and proofreading of proteins by the twin-arginine translocation (Tat) system in bacteria. *Biochim Biophys Acta*, **1808** (3), 876–884.
- Rosano, G.L. and Ceccarelli, E.A. (2014) Recombinant protein expression in *Escherichia coli*: advances and challenges. *Front Microbiol*, **5**, 172.
- Rudolph, R. and Lilie, H. (1996) In vitro folding of inclusion body proteins. *FASEB J*, **10** (1), 49–56.
- Saier, M.H. (2006) Protein Secretion Systems in Gram-Negative Bacteria. *Microbe*, **1**(9), 414–419.
- San-Miguel, T., Pérez-Bermúdez, P. and Gavidia, I. (2013) Production of soluble eukaryotic recombinant proteins in *E. coli* is favoured in early log-phase cultures induced at low temperature. *Springer Plus*, **2** (1), 89.
- Sargent, F., Gohlke, U., Leeuw, E. de, Stanley, N.R., Palmer, T., Saibil, H.R. and Berks, B.C. (2001) Purified components of the *Escherichia coli* Tat protein transport system form a double-layered ring structure. *Eur J Biochem*, **268** (12), 3361–3367.
- Schwechheimer, C. and Kuehn, M.J. (2015) Outer-membrane vesicles from Gram-negative bacteria: biogenesis and functions. *Nat Rev Microbiol*, **13** (10), 605–619.
- Shin, H.-D. and Chen, R.R. (2008) Extracellular recombinant protein production from an *Escherichia coli* lpp deletion mutant. *Biotechnol Bioeng*, **101** (6), 1288–1296.
- Shojaosadati, S.A., Varedi Kolaei, S.M., Babaeipour, V. and Farnoud, A.M. (2008) Recent Advances in High Cell Density Cultivation for Production of Recombinant Protein. *Iran J Biotechnol*, **6** (2), 63–84.
- Silhavy, T.J., Kahne, D. and Walker, S. (2010) The Bacterial Cell Envelope. *CSH Perspect Biol*, **2**(5), a.000414, doi: 10.1101/cshperspect.a000414.
- Sommer, B., Friehs, K. and Flaschel, E. (2010) Efficient production of extracellular proteins with *Escherichia coli* by means of optimized coexpression of bacteriocin release proteins. *J Biotechnol*, **145** (4), 350–358.
- Sørensen, H.P. and Mortensen, K.K. (2005) Soluble expression of recombinant proteins in the cytoplasm of *Escherichia coli*. *Microb Cell Fact*, **4** (1), 1.
- Strandberg, L. and Enfors, S.-O. (1991) Batch and fed batch cultivations for the temperature induced production of a recombinant protein in *Escherichia coli*. *Biotechnol Lett*, **13** (8), 609–614.
- Studier, F.W. (2005) Protein production by auto-induction in high density shaking cultures. *Protein Express Purif*, **41** (1), 207–234.
- Studier, F.W. (2014) Stable expression clones and auto-induction for protein production in *E. coli*, *Methods in molecular biology* (Clifton, N.J.), **1091**, 17–32.
- Sugamata, Y. and Shiba, T. (2005) Improved secretory production of recombinant proteins by random mutagenesis of hlyB, an alpha-hemolysin transporter from *Escherichia coli*. *Appl Environ Microbiol*, **71** (2), 656–662.

- Sugawara, E. and Nikaido, H. (1992) Pore-forming activity of OmpA protein of *Escherichia coli*. *J Biol Chem*, **267** (4), 2507–2511.
- Suit, J.L. and Luria, S.E. (1988) Expression of the kil gene of the ColE1 plasmid in *Escherichia coli* Kilr mutants causes release of periplasmic enzymes and of colicin without cell death. *J Biotechnol*, **170** (10), 4963–4966.
- Takeuchi, S., DiLuzio, W.R., Weibel, D.B. and Whitesides, G.M. (2005) Controlling the shape of filamentous cells of *Escherichia coli*. *Nano Lett*, **5** (9), 1819–1823.
- Tang, J.-B., Yang, H.-M., Song, S.-L., Zhu, P. and Ji, A.-G. (2008) Effect of Glycine and Triton X-100 on secretion and expression of ZZ-EGFP fusion protein. *Food Chem*, **108** (2), 657–662.
- Tosa, T., Sato, T., Mori, T. and Chibata, I. (1974) Basic Studies for Continuous Production of L-Aspartic Acid by Immobilized *Escherichia coli* Cells. *Appl Microbiol*, **27** (5), 886–889.
- Vidal, L., Ferrer, P., Alvaro, G., Benaiges, M.D. and Caminal, G. (2005) Influence of induction and operation mode on recombinant rhamnulose 1-phosphate aldolase production by *Escherichia coli* using the T5 promoter. *J Biotechnol*, **118** (1), 75–87.
- Vohra, A. and Satyanarayana, T. (2003) Phytases: microbial sources, production, purification, and potential biotechnological applications. *Crit Rev Biotechnol*, **23** (1), 29–60.
- Wang, Y. (2002) The function of OmpA in *Escherichia coli*. *Biochem Bioph Res Co*, **292** (2), 396–401.
- Weiner, J. and Zhang, G. (2006) Protein production method utilizing yebf. No. WO 2006017929 A1.
- Wich, G. and Dassler, T. (2008) Process for the fermentative production of antibodies. No. US20080206818 A1.
- Wülfing, C. and Plückthun, A. (1994) Protein folding in the periplasm of *Escherichia coli*. *Mol Microbiol*, **12** (5), 685–692.
- Xiong, A., Yao, Q., Peng, R., Han, P., Cheng, Z. and Li, Y. (2005) High level expression of a recombinant acid phytase gene in *Pichia pastoris*. *J Appl Microbiol*, **98**, 418-428.
- Yamamoto, N., Nakahigashi, K., Nakamichi, T., Yoshino, M., Takai, Y., Touda, Y., Furubayashi, A., Kinjyo, S., Dose, H., Hasegawa, M., Datsenko, K.A., Nakayashiki, T., Tomita, M., Wanner, B.L. and Mori, H. (2009) Update on the Keio collection of *Escherichia coli* single-gene deletion mutants. *Mol Sys Biol*, **5**, 335.
- Yao, M., Zhang, Y., Lu, W., Hu, M., Wang, W. and Liang, A. (2012) Phytases. Crystal structures, protein engineering and potential biotechnological applications. *J Appl Microbiol*, **112**, 1-14.
- Yoon, S., Kim, S. and Kim, J. (2010) Secretory Production of Recombinant Proteins in *Escherichia coli*. *Rec Pat Biotechnol*, **4** (1), 23–29.
- Zhou, M., Guo, Z., Duan, Q., Hardwidge, P.R. and Zhu, G. (2014) *Escherichia coli* type III secretion system 2: a new kind of T3SS?. *Vet Res*, **45**, 32.

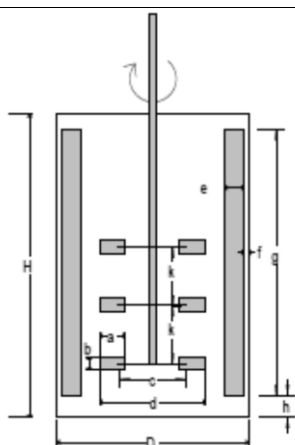
Zhou, S., Yomano, L.P., Saleh, A.Z., Davis, F.C., Aldrich, H.C. and Ingram, L.O. (1999) Enhancement of Expression and Apparent Secretion of *Erwinia chrysanthemi* Endoglucanase (Encoded by celZ) in *Escherichia coli* B. *Appl Environ Microb*, **65** (6), 2439–2445.

Zhu, C., Ruiz-Perez, F., Yang, Z., Mao, Y., Hackethal, V.L., Greco, K.M., Choy, W., Davis, K., Butterson, J.R. and Boedeker, E.C. (2006) Delivery of heterologous protein antigens via hemolysin or autotransporter systems by an attenuated ler mutant of rabbit enteropathogenic *Escherichia coli*. *Vaccine*, **24** (18), 3821–3831.

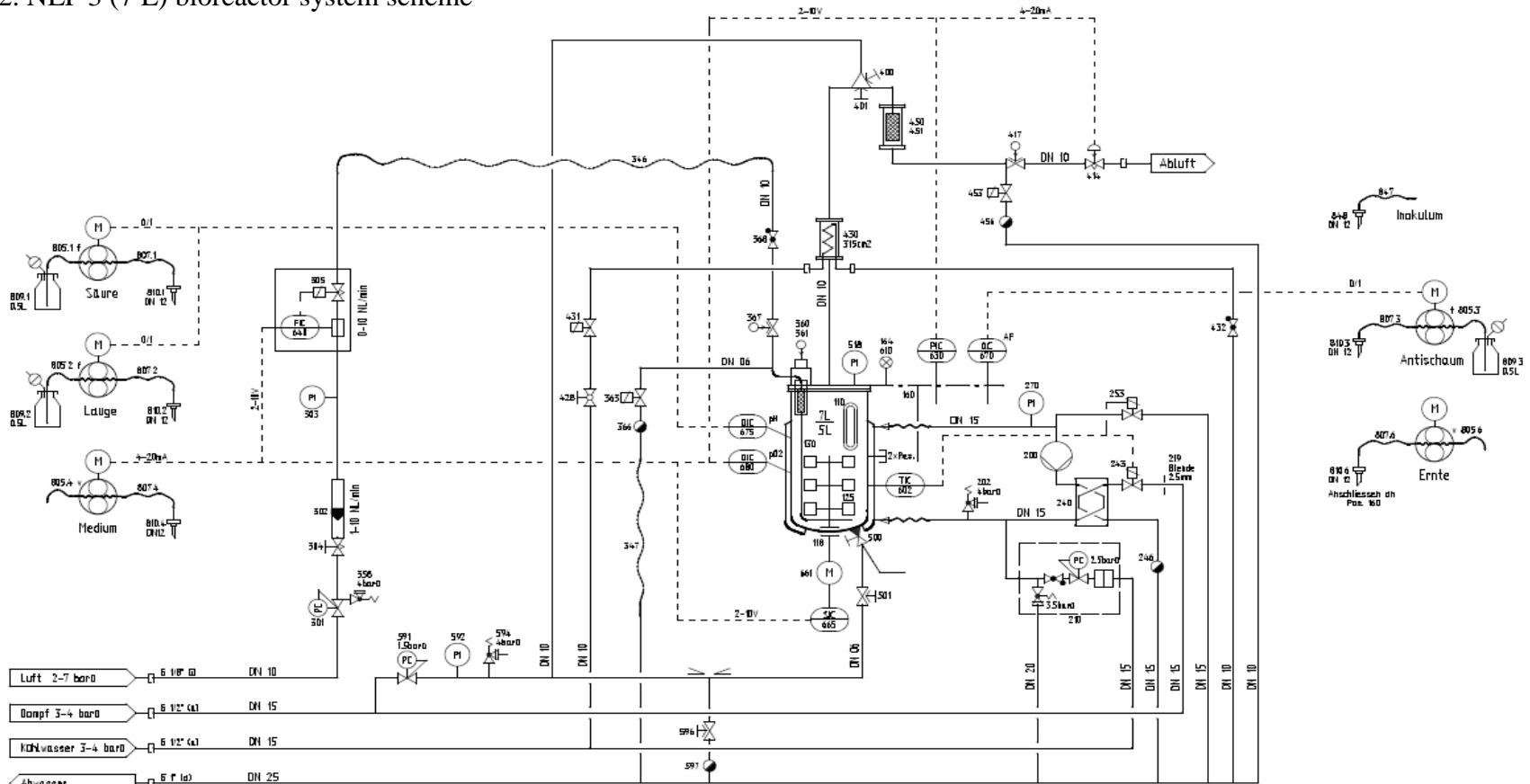
## 7. APPENDIX

### 1. Bioreactors specifications

Bioreactor model	Bioengineering NLF 2 and NLF 3	Bioengineering NLF 1
Process control	BioSCADA Bioengineering	BioSCADA Bioengineering
Total volume	19 L	7 L
Reactor diameter (D)	200 mm	155 mm
Reactor height (H)	605 mm	360 mm
Impeller diameter (d)	70 mm	60 mm
Impeller blade width (a)	18 mm	21 mm
Impeller blade height (b)	14 mm	16 mm
Blade diameter (c)	50 mm	30 mm
Number of blades	6	6
Number of stirrer levels	3	3
Blade bottom and bioreactor bottom distance	102 mm	70 mm
Distance between two stirrers (k)	102 mm	122 mm
Distance between the 2 <sup>nd</sup> stirrer and bioreactor bottom	204 mm	ca. 65 mm
Stirrer blade and air opening	ca. 80 mm	ca.60 mm
Stirring shafts diameter	19 mm	12 mm
Number of baffles	4	4
Baffle height (g)	360 mm	326 mm
Baffle width (e)	20 mm	15 mm
Baffle and bioreactor wall distance (f)	4 mm	3 mm
Baffle and bioreactor bottom distance (h)	ca. 40 mm	0 mm



## 2. NLF 3 (7 L) bioreactor system scheme



Das Unternehmen und dieser Zeichnung sind allein zuständig für alle Copyrights, Patente, Markenrechte, etc. Die Verantwortung für die Einhaltung der geltenden Vorschriften liegt bei den Anwendern dieser Zeichnung.

The copyright in the drawings is reserved for the company. The company is not responsible for the use of the drawings for any purpose other than the one intended. The user is responsible for compliance with all applicable laws and regulations.

© 2010 BiotecLab AG  
BiotecLab AG  
Bioscience and Production of Microbiological Plants  
Sprengelstrasse 1, D-42103 Solingen  
Telefon: 0212 334 111, Fax: 0212 334 111

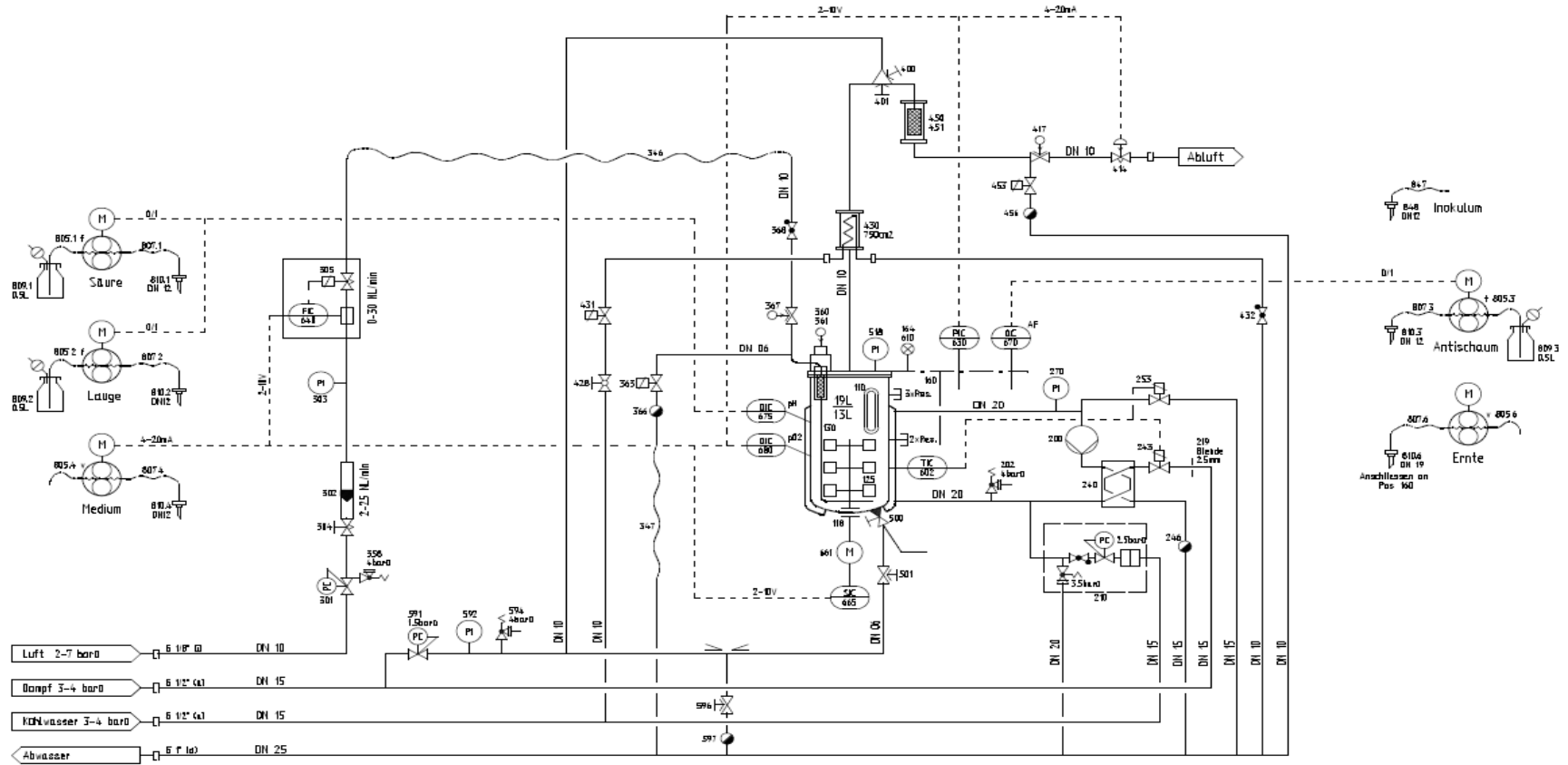
<p>710 Türschlüssel (Schl)</p> <p>TYP SFC 100-1500 rpm OIPC pH OIPC pH2 OIPC → fischeln PFC PIC 6 digitale Eingänge 20 digitale Ausgänge 4 analoge Eingänge 2 analoge Ausgänge RS232-Schnittstelle für WinCC</p> <p>1x230V/140 / 50Hz</p>	<p>709 PC</p> <p>- NLF IM, PD 13891 - NLF IM, PD 13891 - NLF TL, PD 13892</p>	<p>710 SCADA BiotecLab</p> <p>- NLF IM, PD 13891 - NLF IM, PD 13891 - NLF TL, PD 13892</p>
---	---	--

## VOLL STERILISATION

Anderungen: -	-	-	W22193	Ersetzt durch: -												
-	-	-	-	Ersetzt für: -												
<p>PID Fermenter NLF22 7L Universität Bielefeld, Deutschland</p>				<table border="1"> <tr> <td>Gezeichnet</td> <td>DP/DIC</td> <td>hf</td> </tr> <tr> <td>Gepflegt</td> <td>-</td> <td>-</td> </tr> <tr> <td>Normgepr.</td> <td>-</td> <td>-</td> </tr> <tr> <td>Gesehen</td> <td>-</td> <td>-</td> </tr> </table>	Gezeichnet	DP/DIC	hf	Gepflegt	-	-	Normgepr.	-	-	Gesehen	-	-
Gezeichnet	DP/DIC	hf														
Gepflegt	-	-														
Normgepr.	-	-														
Gesehen	-	-														
<p>BiotecLab AG Design and Production of Microbiological Plants Sprengelstrasse 1, D-42103 Solingen, Germany</p>				<p>23892</p>												



### 3. NLF 1 and NLF 2 (19 L) bioreactor system scheme



Das Unternehmen ist ein deutsches Unternehmen und ist ein Unternehmen, das für die Entwicklung und Produktion von Bioreaktoren tätig ist. Die Rechte an diesem Dokument sind Eigentum des Unternehmens. Die Rechte an diesem Dokument sind Eigentum des Unternehmens. Die Rechte an diesem Dokument sind Eigentum des Unternehmens.

700	709	710
<b>Kontrollschrank (Csl)</b> TYP SPC 100-1500 mm DIPC pH DIPC SDC DIPC Antischaum FRC FRC 8 digitale Eingänge 20 digitale Ausgänge 3 analoge Eingänge 3 analoge Ausgänge RS232-Schnittstelle für Vantage 1x230V/40A / 50Hz	PC - NLF RL PD 23891 - NLF TL PD 23892	SCADA (BIMLAB) - NLF RL PD 23891 - NLF TL PD 23892

### VOLL STERILISATION

Änderungen: -	-	-	W22193	Ersetzt durch: -
-	-	-	-	Ersetzt für: -
PID 2x Fermenter NLF22 19L Universität Bielefeld, Deutschland				Gezeichnet: DP/DIC Geprüft: - Normgepr.: - Gesehen: -

Bielefeld, Germany  
 Design and Production of Microbiological Plants  
 Spezialmaschinenbau GmbH  
 Tel: 0531 556 8 256

23891